

Grider, A.; Ramirez, J.A. and Yun, Y.M. "Structural Concrete Design"
Structural Engineering Handbook
Ed. Chen Wai-Fah
Boca Raton: CRC Press LLC, 1999

Structural Concrete Design¹

- 4.1 [Properties of Concrete and Reinforcing Steel](#)
Properties of Concrete • Lightweight Concrete • Heavyweight Concrete • High-Strength Concrete • Reinforcing Steel
 - 4.2 [Proportioning and Mixing Concrete](#)
Proportioning Concrete Mix • Admixtures • Mixing
 - 4.3 [Flexural Design of Beams and One-Way Slabs](#)
Reinforced Concrete Strength Design • Prestressed Concrete Strength Design
 - 4.4 [Columns under Bending and Axial Load](#)
Short Columns under Minimum Eccentricity • Short Columns under Axial Load and Bending • Slenderness Effects • Columns under Axial Load and Biaxial Bending
 - 4.5 [Shear and Torsion](#)
Reinforced Concrete Beams and One-Way Slabs Strength Design • Prestressed Concrete Beams and One-Way Slabs Strength Design
 - 4.6 [Development of Reinforcement](#)
Development of Bars in Tension • Development of Bars in Compression • Development of Hooks in Tension • Splices, Bundled Bars, and Web Reinforcement
 - 4.7 [Two-Way Systems](#)
Definition • Design Procedures • Minimum Slab Thickness and Reinforcement • Direct Design Method • Equivalent Frame Method • Detailing
 - 4.8 [Frames](#)
Analysis of Frames • Design for Seismic Loading
 - 4.9 [Brackets and Corbels](#)
 - 4.10 [Footings](#)
Types of Footings • Design Considerations • Wall Footings • Single-Column Spread Footings • Combined Footings • Two-Column Footings • Strip, Grid, and Mat Foundations • Footings on Piles
 - 4.11 [Walls](#)
Panel, Curtain, and Bearing Walls • Basement Walls • Partition Walls • Shear Walls
 - 4.12 [Defining Terms](#)
- [References](#)
[Further Reading](#)

**Amy Grider and
Julio A. Ramirez**
*School of Civil Engineering,
Purdue University,
West Lafayette, IN*

Young Mook Yun
*Department of Civil Engineering,
National University,
Taegu, South Korea*

¹The material in this chapter was previously published by CRC Press in *The Civil Engineering Handbook*, W.F. Chen, Ed., 1995.

At this point in the history of development of reinforced and prestressed concrete it is necessary to reexamine the fundamental approaches to design of these composite materials. Structural engineering is a worldwide industry. Designers from one nation or a continent are faced with designing a project in another nation or continent. The decades of efforts dedicated to harmonizing concrete design approaches worldwide have resulted in some successes but in large part have led to further differences and numerous different design procedures. It is this abundance of different design approaches, techniques, and code regulations that justifies and calls for the need for a unification of design approaches throughout the entire range of structural concrete, from plain to fully prestressed [5].

The effort must begin at all levels: university courses, textbooks, handbooks, and standards of practice. Students and practitioners must be encouraged to think of a single continuum of structural concrete. Based on this premise, this chapter on concrete design is organized to promote such unification. In addition, effort will be directed at dispelling the present unjustified preoccupation with complex analysis procedures and often highly empirical and incomplete sectional mechanics approaches that tend to both distract the designers from fundamental behavior and impart a false sense of accuracy to beginning designers. Instead, designers will be directed to give careful consideration to overall structure behavior, remarking the adequate flow of forces throughout the entire structure.

4.1 Properties of Concrete and Reinforcing Steel

The designer needs to be knowledgeable about the properties of concrete, reinforcing steel, and prestressing steel. This part of the chapter summarizes the material properties of particular importance to the designer.

4.1.1 Properties of Concrete

Workability is the ease with which the ingredients can be mixed and the resulting mix handled, transported, and placed with little loss in homogeneity. Unfortunately, workability cannot be measured directly. Engineers therefore try to measure the consistency of the concrete by performing a slump test.

The slump test is useful in detecting variations in the uniformity of a mix. In the slump test, a mold shaped as the frustum of a cone, 12 in. (305 mm) high with an 8 in. (203 mm) diameter base and 4 in. (102 mm) diameter top, is filled with concrete (ASTM Specification C143). Immediately after filling, the mold is removed and the change in height of the specimen is measured. The change in height of the specimen is taken as the slump when the test is done according to the ASTM Specification.

A well-proportioned workable mix settles slowly, retaining its original shape. A poor mix crumbles, segregates, and falls apart. The slump may be increased by adding water, increasing the percentage of fines (cement or aggregate), entraining air, or by using an admixture that reduces water requirements; however, these changes may adversely affect other properties of the concrete. In general, the slump specified should yield the desired consistency with the least amount of water and cement.

Concrete should withstand the weathering, chemical action, and wear to which it will be subjected in service over a period of years; thus, **durability** is an important property of concrete. Concrete resistance to freezing and thawing damage can be improved by increasing the watertightness, entraining 2 to 6% air, using an air-entraining agent, or applying a protective coating to the surface. Chemical agents damage or disintegrate concrete; therefore, concrete should be protected with a resistant coating. Resistance to wear can be obtained by use of a high-strength, dense concrete made with hard aggregates.

Excess water leaves voids and cavities after evaporation, and water can penetrate or pass through the concrete if the voids are interconnected. Watertightness can be improved by entraining air or reducing water in the mix, or it can be prolonged through curing.

Volume change of concrete should be considered, since expansion of the concrete may cause buckling and drying shrinkage may cause cracking. Expansion due to alkali-aggregate reaction can be avoided by using nonreactive aggregates. If reactive aggregates must be used, expansion may be reduced by adding pozzolanic material (e.g., fly ash) to the mix. Expansion caused by heat of hydration of the cement can be reduced by keeping cement content as low as possible; using Type IV cement; and chilling the aggregates, water, and concrete in the forms. Expansion from temperature increases can be reduced by using coarse aggregate with a lower coefficient of thermal expansion. Drying shrinkage can be reduced by using less water in the mix, using less cement, or allowing adequate moist curing. The addition of pozzolans, unless allowing a reduction in water, will increase drying shrinkage. Whether volume change causes damage usually depends on the restraint present; consideration should be given to eliminating restraints or resisting the stresses they may cause [8].

Strength of concrete is usually considered its most important property. The **compressive strength** at 28 d is often used as a measure of strength because the strength of concrete usually increases with time. The compressive strength of concrete is determined by testing specimens in the form of **standard cylinders** as specified in ASTM Specification C192 for research testing or C31 for field testing. The test procedure is given in ASTM C39. If drilled cores are used, ASTM C42 should be followed.

The suitability of a mix is often desired before the results of the 28-d test are available. A formula proposed by W. A. Slater estimates the 28-d compressive strength of concrete from its 7-d strength:

$$S_{28} = S_7 + 30\sqrt{S_7} \quad (4.1)$$

where

S_{28} = 28-d compressive strength, psi

S_7 = 7-d compressive strength, psi

Strength can be increased by decreasing **water-cement ratio**, using higher strength aggregate, using a pozzolan such as fly ash, grading the aggregates to produce a smaller percentage of voids in the concrete, moist curing the concrete after it has set, and vibrating the concrete in the forms. The short-time strength can be increased by using Type III portland cement, accelerating admixtures, and by increasing the curing temperature.

The stress-strain curve for concrete is a curved line. Maximum stress is reached at a strain of 0.002 in./in., after which the curve descends.

The **modulus of elasticity**, E_c , as given in ACI 318-89 (Revised 92), *Building Code Requirements for Reinforced Concrete* [1], is:

$$E_c = w_c^{1.5} 33\sqrt{f'_c} \text{ lb/ft}^3 \text{ and psi} \quad (4.2a)$$

$$E_c = w_c^{1.5} 0.043\sqrt{f'_c} \text{ kg/m}^3 \text{ and MPa} \quad (4.2b)$$

where

w_c = unit weight of concrete

f'_c = compressive strength at 28 d

Tensile strength of concrete is much lower than the compressive strength—about $7\sqrt{f'_c}$ for the higher-strength concretes and $10\sqrt{f'_c}$ for the lower-strength concretes.

Creep is the increase in strain with time under a constant load. Creep increases with increasing water-cement ratio and decreases with an increase in relative humidity. Creep is accounted for in design by using a reduced modulus of elasticity of the concrete.

4.1.2 Lightweight Concrete

Structural lightweight concrete is usually made from aggregates conforming to ASTM C330 that are usually produced in a kiln, such as expanded clays and shales. Structural lightweight concrete has a density between 90 and 120 lb/ft³ (1440 to 1920 kg/m³).

Production of lightweight concrete is more difficult than normal-weight concrete because the aggregates vary in absorption of water, specific gravity, moisture content, and amount of grading of undersize. Slump and unit weight tests should be performed often to ensure uniformity of the mix. During placing and finishing of the concrete, the aggregates may float to the surface. Workability can be improved by increasing the percentage of fines or by using an air-entraining admixture to incorporate 4 to 6% air. Dry aggregate should not be put into the mix because it will continue to absorb moisture and cause the concrete to harden before placement is completed. Continuous water curing is important with lightweight concrete.

No-fines concrete is obtained by using pea gravel as the coarse aggregate and 20 to 30% entrained air instead of sand. It is used for low dead weight and insulation when strength is not important. This concrete weighs from 105 to 118 lb/ft³ (1680 to 1890 kg/m³) and has a compressive strength from 200 to 1000 psi (1 to 7 MPa).

A porous concrete made by gap grading or single-size aggregate grading is used for low conductivity or where drainage is needed.

Lightweight concrete can also be made with gas-forming or foaming agents which are used as admixtures. Foam concretes range in weight from 20 to 110 lb/ft³ (320 to 1760 kg/m³). The modulus of elasticity of lightweight concrete can be computed using the same formula as normal concrete. The shrinkage of lightweight concrete is similar to or slightly greater than for normal concrete.

4.1.3 Heavyweight Concrete

Heavyweight concretes are used primarily for shielding purposes against gamma and x-radiation in nuclear reactors and other structures. Barite, limonite and magnetite, steel punchings, and steel shot are typically used as aggregates. Heavyweight concretes weigh from 200 to 350 lb/ft³ (3200 to 5600 kg/m³) with strengths from 3200 to 6000 psi (22 to 41 MPa). Gradings and mix proportions are similar to those for normal weight concrete. Heavyweight concretes usually do not have good resistance to weathering or abrasion.

4.1.4 High-Strength Concrete

Concretes with strengths in excess of 6000 psi (41 MPa) are referred to as high-strength concretes. Strengths up to 18,000 psi (124 MPa) have been used in buildings.

Admixtures such as superplasticizers, [silica fume](#), and supplementary cementing materials such as fly ash improve the dispersion of cement in the mix and produce workable concretes with lower water-cement ratios, lower void ratios, and higher strength. Coarse aggregates should be strong fine-grained gravel with rough surfaces.

For concrete strengths in excess of 6000 psi (41 MPa), the modulus of elasticity should be taken as

$$E_c = 40,000\sqrt{f'_c} + 1.0 \times 10^6 \quad (4.3)$$

where

f'_c = compressive strength at 28 d, psi [4]

The shrinkage of high-strength concrete is about the same as that for normal concrete.

4.1.5 Reinforcing Steel

Concrete can be reinforced with welded wire fabric, deformed reinforcing bars, and prestressing tendons.

Welded wire fabric is used in thin [slabs](#), thin shells, and other locations where space does not allow the placement of [deformed bars](#). Welded wire fabric consists of cold drawn wire in orthogonal patterns—square or rectangular and resistance-welded at all intersections. The wire may be smooth (ASTM A185 and A82) or deformed (ASTM A497 and A496). The wire is specified by the symbol W for smooth wires or D for deformed wires followed by a number representing the cross-sectional area in hundredths of a square inch. On design drawings it is indicated by the symbol WWF followed by spacings of the wires in the two 90° directions. Properties for welded wire fabric are given in [Table 4.1](#).

TABLE 4.1 Wire and Welded Wire Fabric Steels

AST designation	Wire size designation	Minimum yield stress, ^a f_y		Minimum tensile strength	
		ksi	MPa	ksi	MPa
A82-79 (cold-drawn wire) (properties apply when material is to be used for fabric)	W1.2 and larger ^b	65	450	75	520
	Smaller than W1.2	56	385	70	480
A185-79 (welded wire fabric)	Same as A82; this is A82 material fabricated into sheet (so-called “mesh”) by the process of electric welding				
A496-78 (deformed steel wire) (properties apply when material is to be used for fabric)	D1-D31 ^c	70	480	80	550
A497-79	Same as A82 or A496; this specification applies for fabric made from A496, or from a combination of A496 and A82 wires				

^a The term “yield stress” refers to either *yield point*, the well-defined deviation from perfect elasticity, or *yield strength*, the value obtained by a specified offset strain for material having no well-defined yield point.

^b The W number represents the nominal cross-sectional area in square inches multiplied by 100, for smooth wires.

^c The D number represents the nominal cross-sectional area in square inches multiplied by 100, for deformed wires.

The deformations on a deformed reinforcing bar inhibit longitudinal movement of the bar relative to the concrete around it. [Table 4.2](#) gives dimensions and weights of these bars. Reinforcing bar steel can be made of billet steel of grades 40 and 60 having minimum specific yield stresses of 40,000 and 60,000 psi, respectively (276 and 414 MPa) (ASTM A615) or low-alloy steel of grade 60, which is intended for applications where welding and/or bending is important (ASTM A706). Presently, grade 60 billet steel is the most predominantly used for construction.

Prestressing tendons are commonly in the form of individual wires or groups of wires. Wires of different strengths and properties are available with the most prevalent being the 7-wire low-relaxation strand conforming to ASTM A416. ASTM A416 also covers a stress-relieved strand, which is seldom used in construction nowadays. Properties of standard prestressing strands are given in [Table 4.3](#). Prestressing tendons could also be bars; however, this is not very common. Prestressing bars meeting ASTM A722 have been used in connections between members.

The modulus of elasticity for non-prestressed steel is 29,000,000 psi (200,000 MPa). For prestressing steel, it is lower and also variable, so it should be obtained from the manufacturer. For 7-wires strands conforming to ASTM A416, the modulus of elasticity is usually taken as 27,000,000 psi (186,000 MPa).

TABLE 4.2 Reinforcing Bar Dimensions and Weights

Bar number	Nominal dimensions				Weight	
	Diameter		Area		(lb/ft)	(kg/m)
	(in.)	(mm)	(in. ²)	(cm ²)		
3	0.375	9.5	0.11	0.71	0.376	0.559
4	0.500	12.7	0.20	1.29	0.668	0.994
5	0.625	15.9	0.31	2.00	1.043	1.552
6	0.750	19.1	0.44	2.84	1.502	2.235
7	0.875	22.2	0.60	3.87	2.044	3.041
8	1.000	25.4	0.79	5.10	2.670	3.973
9	1.128	28.7	1.00	6.45	3.400	5.059
10	1.270	32.3	1.27	8.19	4.303	6.403
11	1.410	35.8	1.56	10.06	5.313	7.906
14	1.693	43.0	2.25	14.52	7.65	11.38
18	2.257	57.3	4.00	25.81	13.60	20.24

TABLE 4.3 Standard Prestressing Strands, Wires, and Bars

Tendon type	Grade	Nominal dimension		Weight plf
	f_{pu} ksi	Diameter in.	Area in. ²	
Seven-wire strand	250	1/4	0.036	0.12
	270	3/8	0.085	0.29
	250	3/8	0.080	0.27
	270	1/2	0.153	0.53
	250	1/2	0.144	0.49
	270	0.6	0.215	0.74
	250	0.6	0.216	0.74
Prestressing wire	250	0.196	0.0302	0.10
	240	0.250	0.0491	0.17
	235	0.276	0.0598	0.20
Deformed prestressing bars	157	5/8	0.28	0.98
	150	1	0.85	3.01
	150	1 1/4	1.25	4.39
	150	1 3/8	1.58	5.56

4.2 Proportioning and Mixing Concrete

4.2.1 Proportioning Concrete Mix

A concrete mix is specified by the weight of water, sand, coarse aggregate, and admixture to be used per 94-pound bag of cement. The type of cement (Table 4.4), modulus of the aggregates, and maximum size of the aggregates (Table 4.5) should also be given. A mix can be specified by the weight ratio of cement to sand to coarse aggregate with the minimum amount of cement per cubic yard of concrete.

In proportioning a concrete mix, it is advisable to make and test trial batches because of the many variables involved. Several trial batches should be made with a constant water-cement ratio but varying ratios of aggregates to obtain the desired workability with the least cement. To obtain results similar to those in the field, the trial batches should be mixed by machine.

When time or other conditions do not allow proportioning by the trial batch method, Table 4.6 may be used. Start with mix B corresponding to the appropriate maximum size of aggregate. Add just enough water for the desired workability. If the mix is undersanded, change to mix A; if oversanded, change to mix C. Weights are given for dry sand. For damp sand, increase the weight of sand 10 lb, and for very wet sand, 20 lb, per bag of cement.

TABLE 4.4 Types of Portland Cement^a

Type	Usage
I	Ordinary construction where special properties are not required
II	Ordinary construction when moderate sulfate resistance or moderate heat of hydration is desired
III	When high early strength is desired
IV	When low heat of hydration is desired
V	When high sulfate resistance is desired

^a According to ASTM C150.**TABLE 4.5** Recommended Maximum Sizes of Aggregate^a

Minimum dimension of section, in.	Maximum size, in., of aggregate for:		
	Reinforced-concrete beams, columns, walls	Heavily reinforced slabs	Lightly reinforced or unreinforced slabs
5 or less	...	3/4 - 1 1/2	3/4 - 1 1/2
6-11	3/4 - 1 1/2	1 1/2	1 1/2 - 3
12-29	1 1/2 - 3	3	3 - 6
30 or more	1 1/2 - 3	3	6

^a *Concrete Manual*. U.S. Bureau of Reclamation.**TABLE 4.6** Typical Concrete Mixes^a

Maximum size of aggregate, in.	Mix designation	Bags of cement per yd ³ of concrete	Aggregate, lb per bag of cement		
			Sand		
			Air-entrained concrete	Concrete without air	Gravel or crushed stone
1/2	A	7.0	235	245	170
	B	6.9	225	235	190
	C	6.8	225	235	205
3/4	A	6.6	225	235	225
	B	6.4	225	235	245
	C	6.3	215	225	265
1	A	6.4	225	235	245
	B	6.2	215	225	275
	C	6.1	205	215	290
1 1/2	A	6.0	225	235	290
	B	5.8	215	225	320
	C	5.7	205	215	345
2	A	5.7	225	235	330
	B	5.6	215	225	360
	C	5.4	205	215	380

^a *Concrete Manual*. U.S. Bureau of Reclamation.

4.2.2 Admixtures

Admixtures may be used to modify the properties of concrete. Some types of admixtures are set accelerators, water reducers, air-entraining agents, and waterproofers. Admixtures are generally helpful in improving quality of the concrete. However, if admixtures are not properly used, they could have undesirable effects; it is therefore necessary to know the advantages and limitations of the proposed admixture. The ASTM Specifications cover many of the admixtures.

Set accelerators are used (1) when it takes too long for concrete to set naturally; such as in cold weather, or (2) to accelerate the rate of strength development. Calcium chloride is widely used as a set accelerator. If not used in the right quantities, it could have harmful effects on the concrete and [reinforcement](#).

Water reducers lubricate the mix and permit easier placement of the concrete. Since the workability of a mix can be improved by a chemical agent, less water is needed. With less water but the same

cement content, the strength is increased. Since less water is needed, the cement content could also be decreased, which results in less shrinkage of the hardened concrete. Some water reducers also slow down the concrete set, which is useful in hot weather and integrating consecutive pours of the concrete.

Air-entraining agents are probably the most widely used type of admixture. Minute bubbles of air are entrained in the concrete, which increases the resistance of the concrete to freeze-thaw cycles and the use of ice-removal salts.

Waterproofing chemicals are often applied as surface treatments, but they can be added to the concrete mix. If applied properly and uniformly, they can prevent water from penetrating the concrete surface. Epoxies can also be used for waterproofing. They are more durable than silicone coatings, but they may be more costly. Epoxies can also be used for protection of wearing surfaces, patching cavities and [cracks](#), and glue for connecting pieces of hardened concrete.

4.2.3 Mixing

Materials used in making concrete are stored in batch plants that have weighing and control equipment and bins for storing the cement and aggregates. Proportions are controlled by automatic or manually operated scales. The water is measured out either from measuring tanks or by using water meters.

Machine mixing is used whenever possible to achieve uniform consistency. The revolving drum-type mixer and the countercurrent mixer, which has mixing blades rotating in the opposite direction of the drum, are commonly used.

Mixing time, which is measured from the time all ingredients are in the drum, “should be at least 1.5 minutes for a 1-yd³ mixer, plus 0.5 min for each cubic yard of capacity over 1 yd³” [ACI 304-73, 1973]. It also is recommended to set a maximum on mixing time since overmixing may remove entrained air and increase fines, thus requiring more water for workability; three times the minimum mixing time can be used as a guide.

[Ready-mixed concrete](#) is made in plants and delivered to job sites in mixers mounted on trucks. The concrete can be mixed en route or upon arrival at the site. Concrete can be kept plastic and workable for as long as 1.5 hours by slow revolving of the mixer. Mixing time can be better controlled if water is added and mixing started upon arrival at the job site, where the operation can be inspected.

4.3 Flexural Design of [Beams](#) and One-Way Slabs

4.3.1 Reinforced Concrete Strength Design

The basic assumptions made in flexural design are:

1. Sections perpendicular to the axis of bending that are plane before bending remain plane after bending.
2. A perfect [bond](#) exists between the reinforcement and the concrete such that the strain in the reinforcement is equal to the strain in the concrete at the same level.
3. The strains in both the concrete and reinforcement are assumed to be directly proportional to the distance from the neutral axis (ACI 10.2.2) [1].
4. Concrete is assumed to fail when the compressive strain reaches 0.003 (ACI 10.2.3).
5. The tensile strength of concrete is neglected (ACI 10.2.5).
6. The stresses in the concrete and reinforcement can be computed from the strains using stress-strain curves for concrete and steel, respectively.

7. The compressive stress-strain relationship for concrete may be assumed to be rectangular, trapezoidal, parabolic, or any other shape that results in prediction of strength in substantial agreement with the results of compressive tests (ACI 10.2.6). ACI 10.2.7 outlines the use of a rectangular compressive stress distribution which is known as the **Whitney rectangular stress block**. For other stress distributions see *Reinforced Concrete Mechanics and Design* by James G. MacGregor [8].

Analysis of Rectangular Beams with Tension Reinforcement Only

Equations for M_n and ϕM_n : Tension Steel Yielding Consider the beam shown in Figure 4.1. The compressive force, C , in the concrete is

$$C = (0.85 f'_c) ba \quad (4.4)$$

The tension force, T , in the steel is

$$T = A_s f_y \quad (4.5)$$

For equilibrium, $C = T$, so the depth of the equivalent rectangular stress block, a , is

$$a = \frac{A_s f_y}{0.85 f'_c b} \quad (4.6)$$

Noting that the internal forces C and T form an equivalent force-couple system, the internal moment is

$$M_n = T(d - a/2) \quad (4.7)$$

or

$$M_n = C(d - a/2)$$

ϕM_n is then

$$\phi M_n = \phi T(d - a/2) \quad (4.8)$$

or

$$\phi M_n = \phi C(d - a/2)$$

where $\phi = 0.90$.

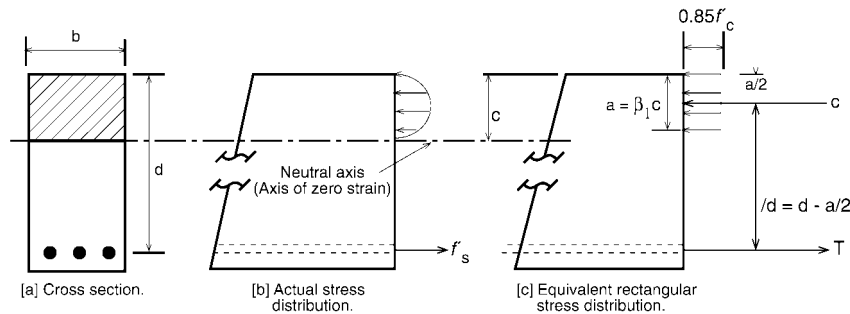

FIGURE 4.1: Stresses and forces in a rectangular beam.

Equation for M_n and ϕM_n : Tension Steel Elastic The internal forces and equilibrium are given by:

$$\begin{aligned} C &= T \\ 0.85 f'_c b a &= A_s f_s \\ 0.85 f'_c b a &= \rho b d E_s \varepsilon_s \end{aligned} \quad (4.9)$$

From strain compatibility (see Figure 4.1),

$$\varepsilon_s = \varepsilon_{cu} \left(\frac{d - c}{c} \right) \quad (4.10)$$

Substituting ε_s into the equilibrium equation, noting that $a = \beta_1 c$, and simplifying gives

$$\left(\frac{0.85 f'_c}{\rho E_s \varepsilon_{cu}} \right) a^2 + (d)a - \beta_1 d^2 = 0 \quad (4.11)$$

which can be solved for a . Equations 4.7 and 4.8 can then be used to obtain M_n and ϕM_n .

Reinforcement Ratios The reinforcement ratio, ρ , is used to represent the relative amount of tension reinforcement in a beam and is given by

$$\rho = \frac{A_s}{bd} \quad (4.12)$$

At the balanced strain condition the maximum strain, ε_{cu} , at the extreme concrete compression fiber reaches 0.003 just as the tension steel reaches the strain $\varepsilon_y = f_y/E_s$. The reinforcement ratio in the balanced strain condition, ρ_b , can be obtained by applying equilibrium and compatibility conditions. From the linear strain condition, Figure 4.1,

$$\frac{c_b}{d} = \frac{\varepsilon_{cu}}{\varepsilon_{cu} + \varepsilon_y} = \frac{0.003}{0.003 + \frac{f_y}{29,000,000}} = \frac{87,000}{87,000 + f_y} \quad (4.13)$$

The compressive and tensile forces are:

$$\begin{aligned} C_b &= 0.85 f'_c b \beta_1 c_b \\ T_b &= f_y A_{sb} = \rho_b b d f_y \end{aligned} \quad (4.14)$$

Equating C_b to T_b and solving for ρ_b gives

$$\rho_b = \frac{0.85 f'_c \beta_1}{f_y} \left(\frac{c_b}{d} \right) \quad (4.15)$$

which on substitution of Equation 4.13 gives

$$\rho_b = \frac{0.85 f'_c \beta_1}{f_y} \left(\frac{87,000}{87,000 + f_y} \right) \quad (4.16)$$

ACI 10.3.3 limits the amount of reinforcement in order to prevent nonductile behavior:

$$\max \rho = 0.75 \rho_b \quad (4.17)$$

ACI 10.5 requires a minimum amount of flexural reinforcement:

$$\rho_{\min} = \frac{200}{f_y} \quad (4.18)$$

Analysis of Beams with Tension and Compression Reinforcement

For the analysis of doubly reinforced beams, the cross-section will be divided into two beams. Beam 1 consists of the compression reinforcement at the top and sufficient steel at the bottom so that $T_1 = C_s$; beam 2 consists of the concrete web and the remaining tensile reinforcement, as shown in Figure 4.2

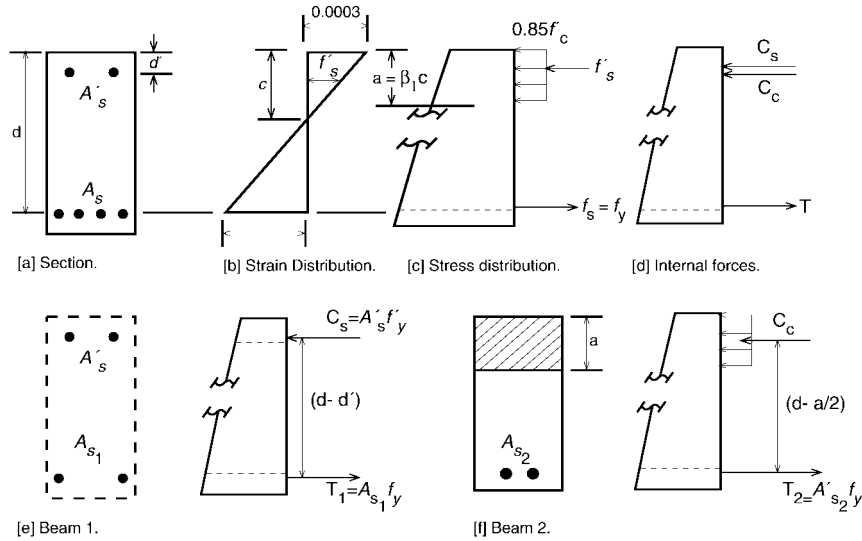

FIGURE 4.2: Strains, stresses, and forces in beam with compression reinforcement.

Equation for M_n : Compression Steel Yields The area of tension steel in beam 1 is obtained by setting $T_1 = C_s$, which gives $A_{s1} = A'_s$. The nominal moment capacity of beam 1 is then

$$M_{n1} = A'_s f_y (d - d') \quad (4.19)$$

Beam 2 consists of the concrete and the remaining steel, $A_{s2} = A_s - A_{s1} = A_s - A'_s$. The compression force in the concrete is

$$C = 0.85 f'_c b a \quad (4.20)$$

and the tension force in the steel for beam 2 is

$$T = (A_s - A'_s) f_y \quad (4.21)$$

The depth of the compression stress block is then

$$a = \frac{(A_s - A'_s) f_y}{0.85 f'_c b} \quad (4.22)$$

Therefore, the nominal moment capacity for beam 2 is

$$M_{n2} = (A_s - A'_s) f_y (d - a/2) \quad (4.23)$$

The total moment capacity for a doubly reinforced beam with compression steel yielding is the summation of the moment capacity for beam 1 and beam 2; therefore,

$$M_n = A'_s f_y (d - d') + (A_s - A'_s) f_y (d - a/2) \quad (4.24)$$

Equation for M_n : Compression Steel Does Not Yield Assuming that the tension steel yields, the internal forces in the beam are

$$\begin{aligned} T &= A_s f_y \\ C_c &= 0.85 f'_c b a \\ C_s &= A'_s (E_s \varepsilon'_s) \end{aligned} \quad (4.25)$$

where

$$\varepsilon'_s = \left(1 - \frac{\beta_1 d'}{a}\right) (0.003) \quad (4.26)$$

From equilibrium, $C_s + C_c = T$ or

$$0.85 f'_c b a + A'_s E_s \left(1 - \frac{\beta_1 d'}{a}\right) (0.003) = A_s f_y \quad (4.27)$$

This can be rewritten in quadratic form as

$$(0.85 f'_c b) a^2 + (0.003 A'_s E_s - A_s F_y) a - (0.003 A'_s E_s \beta_1 d') = 0 \quad (4.28)$$

where a can be calculated by means of the quadratic equation. Therefore, the nominal moment capacity in a doubly reinforced concrete beam where the compression steel does not yield is

$$M_n = C_c \left(d - \frac{a}{2}\right) + C_s (d - d') \quad (4.29)$$

Reinforcement Ratios The reinforcement ratio at the balanced strain condition can be obtained in a similar manner as that for beams with tension steel only. For compression steel yielding, the balanced ratio is

$$(\rho - \rho')_b = \frac{0.85 f'_c \beta_1}{f_y} \left(\frac{87,000}{87,000 + f_y}\right) \quad (4.30)$$

For compression steel not yielding, the balanced ratio is

$$\left(\rho - \frac{\rho' f'_s}{f_y}\right)_b = \frac{0.85 f'_c \beta_1}{f_y} \left(\frac{87,000}{87,000 + f_y}\right) \quad (4.31)$$

The maximum and minimum reinforcement ratios as given in ACI 10.3.3 and 10.5 are

$$\begin{aligned} \rho_{\max} &= 0.75 \rho_b \\ \rho_{\min} &= \frac{200}{f_y} \end{aligned} \quad (4.32)$$

4.3.2 Prestressed Concrete Strength Design

Elastic Flexural Analysis

In developing elastic equations for prestress, the effects of prestress force, dead load moment, and live load moment are calculated separately, and then the separate stresses are superimposed, giving

$$f = -\frac{F}{A} \pm \frac{Fey}{I} \pm \frac{My}{I} \quad (4.33)$$

where (–) indicates compression and (+) indicates tension. It is necessary to check that the stresses in the extreme fibers remain within the ACI-specified limits under any combination of loadings that many occur. The stress limits for the concrete and prestressing tendons are specified in ACI 18.4 and 18.5 [1].

ACI 18.2.6 states that the loss of area due to open ducts shall be considered when computing section properties. It is noted in the commentary that section properties may be based on total area if the effect of the open duct area is considered negligible. In pretensioned members and in **post-tensioned** members after grouting, section properties can be based on gross sections, net sections, or effective sections using the transformed areas of bonded tendons and nonprestressed reinforcement.

Flexural Strength

The strength of a prestressed beam can be calculated using the methods developed for ordinary reinforced concrete beams, with modifications to account for the differing nature of the stress-strain relationship of prestressing steel compared with ordinary reinforcing steel.

A prestressed beam will fail when the steel reaches a stress f_{ps} , generally less than the tensile strength f_{pu} . For rectangular cross-sections the nominal flexural strength is

$$M_n = A_{ps} f_{ps} d - \frac{a}{2} \quad (4.34)$$

where

$$a = \frac{A_{ps} f_{ps}}{0.85 f'_c b} \quad (4.35)$$

The steel stress f_{ps} can be found based on strain compatibility or by using approximate equations such as those given in ACI 18.7.2. The equations in ACI are applicable only if the **effective prestress** in the steel, f_{se} , which equals P_e/A_{ps} , is not less than 0.5 f_{pu} . The ACI equations are as follows.

(a) For members with bonded tendons:

$$f_{ps} = f_{pu} \left(1 - \frac{\gamma_p}{\beta_1} \left[\rho \frac{f_{pu}}{f'_c} + \frac{d}{d_p} (\omega - \omega') \right] \right) \quad (4.36)$$

If any compression reinforcement is taken into account when calculating f_{ps} with Equation 4.36, the following applies:

$$\left[\rho_p \frac{f_{pu}}{f'_c} + \frac{d}{d_p} (\omega - \omega') \right] \geq 0.17 \quad (4.37)$$

and

$$d' \leq 0.15 d_p$$

(b) For members with **unbonded tendons** and with a span-to-depth ratio of 35 or less:

$$f_{ps} = f_{se} + 10,000 + \frac{f'_c}{100\rho_p} \leq \left\{ \begin{array}{l} f_{py} \\ f_{se} + 60,000 \end{array} \right\} \quad (4.38)$$

(c) For members with unbonded tendons and with a span-to-depth ratio greater than 35:

$$f_{ps} = f_{se} + 10,000 + \frac{f'_c}{300\rho_p} \leq \left\{ \begin{array}{l} f_{py} \\ f_{se} + 30,000 \end{array} \right\} \quad (4.39)$$

The flexural strength is then calculated from Equation 4.34. The design strength is equal to ϕM_n , where $\phi = 0.90$ for flexure.

Reinforcement Ratios

ACI requires that the total amount of prestressed and nonprestressed reinforcement be adequate to develop a factored load at least 1.2 times the **cracking load** calculated on the basis of a modulus of rupture of $7.5 \sqrt{f'_c}$.

To control cracking in members with unbonded tendons, some bonded reinforcement should be uniformly distributed over the tension zone near the extreme tension fiber. ACI specifies the minimum amount of bonded reinforcement as

$$A_s = 0.004A \quad (4.40)$$

where A is the area of the cross-section between the flexural tension face and the center of gravity of the gross cross-section. ACI 19.9.4 gives the minimum length of the bonded reinforcement.

To ensure adequate **ductility**, ACI 18.8.1 provides the following requirement:

$$\left\{ \begin{array}{l} \omega_p + \left(\frac{d}{d_p} \right) (\omega - \omega') \\ \omega_{pw} + \left(\frac{d}{d_p} \right) (\omega_w - \omega'_w) \end{array} \right\} \leq 0.36\beta_1 \quad (4.41)$$

ACI allows each of the terms on the left side to be set equal to $0.85 a/d_p$ in order to simplify the equation.

When a reinforcement ratio greater than $0.36 \beta_1$ is used, ACI 18.8.2 states that the design moment strength shall not be greater than the moment strength based on the compression portion of the moment couple.

4.4 Columns under Bending and Axial Load

4.4.1 Short Columns under Minimum Eccentricity

When a symmetrical column is subjected to a concentric axial load, P , longitudinal strains develop uniformly across the section. Because the steel and concrete are bonded together, the strains in the concrete and steel are equal. For any given strain it is possible to compute the stresses in the concrete and steel using the stress-strain curves for the two materials. The forces in the concrete and steel are equal to the stresses multiplied by the corresponding areas. The total load on the column is the sum of the forces in the concrete and steel:

$$P_o = 0.85 f'_c (A_g - A_{st}) + f_y A_{st} \quad (4.42)$$

To account for the effect of incidental moments, ACI 10.3.5 specifies that the maximum design axial load on a column be, for spiral columns,

$$\phi P_{n(\max)} = 0.85\phi [0.85 f'_c (A_g - A_{st}) + f_y A_{st}] \quad (4.43)$$

and for tied columns,

$$\phi P_{n(\max)} = 0.80\phi [0.85 f'_c (A_g - A_{st}) + f_y A_{st}] \quad (4.44)$$

For high values of axial load, ϕ values of 0.7 and 0.75 are specified for tied and spiral columns, respectively (ACI 9.3.2.2b) [1].

Short columns are sufficiently stocky such that slenderness effects can be ignored.

4.4.2 Short Columns under Axial Load and Bending

Almost all [compression members](#) in concrete structures are subjected to moments in addition to axial loads. Although it is possible to derive equations to evaluate the strength of columns subjected to combined bending and axial loads, the equations are tedious to use. For this reason, [interaction diagrams](#) for columns are generally computed by assuming a series of strain distributions, each corresponding to a particular point on the interaction diagram, and computing the corresponding values of P and M . Once enough such points have been computed, the results are summarized in an interaction diagram. For examples on determining the interaction diagram, see *Reinforced Concrete Mechanics and Design* by James G. MacGregor [8] or *Reinforced Concrete Design* by Chu-Kia Wang and Charles G. Salmon [11].

Figure 4.3 illustrates a series of strain distributions and the resulting points on the interaction diagram. Point A represents pure axial compression. Point B corresponds to crushing at one face and zero tension at the other. If the tensile strength of concrete is ignored, this represents the onset of cracking on the bottom face of the section. All points lower than this in the interaction diagram represent cases in which the section is partially cracked. Point C, the farthest right point, corresponds to the balanced strain condition and represents the change from compression failures for higher loads and tension failures for lower loads. Point D represents a strain distribution where the reinforcement has been strained to several times the yield strain before the concrete reaches its crushing strain.

The horizontal axis of the interaction diagram corresponds to pure bending where $\phi = 0.9$. A transition is required from $\phi = 0.7$ or 0.75 for high axial loads to $\phi = 0.9$ for pure bending. The change in ϕ begins at a capacity ϕP_a , which equals the smaller of the balanced load, ϕP_b , or $0.1 f'_c A_g$. Generally, ϕP_b exceeds $0.1 f'_c A_g$ except for a few nonrectangular columns.

ACI publication SP-17A(85), *A Design Handbook for Columns*, contains nondimensional interaction diagrams as well as other design aids for columns [2].

4.4.3 Slenderness Effects

ACI 10.11 describes an approximate slenderness-effect design procedure based on the moment magnifier concept. The moments are computed by ordinary frame analysis and multiplied by a moment magnifier that is a function of the factored axial load and the critical buckling load of the column. The following gives a summary of the moment magnifier design procedure for slender columns in frames.

1. *Length of Column.* The unsupported length, l_u , is defined in ACI 10.11.1 as the clear distance between floor slabs, beams, or other members capable of giving lateral support to the column.
2. *Effective length.* The effective length factors, k , used in calculating δ_b shall be between 0.5 and 1.0 (ACI 10.11.2.1). The effective length factors used to compute δ_s shall be greater than 1 (ACI 10.11.2.2). The effective length factors can be estimated using ACI Fig. R10.11.2 or using ACI Equations (A)–(E) given in ACI R10.11.2. These two procedures require that the ratio, ψ , of the columns and beams be known:

$$\psi = \frac{\sum (E_c I_c / l_c)}{\sum (E_b I_b / l_b)} \quad (4.45)$$

In computing ψ it is acceptable to take the EI of the column as the uncracked gross $E_c I_g$ of the columns and the EI of the beam as $0.5 E_c I_g$.

3. *Definition of braced and unbraced frames.* The ACI Commentary suggests that a frame is braced if either of the following are satisfied:

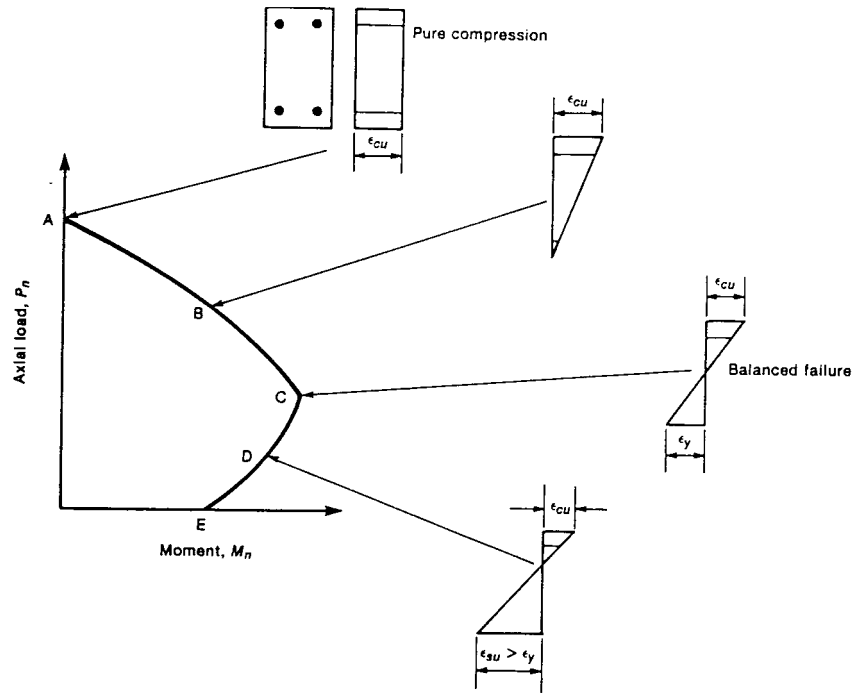

FIGURE 4.3: Strain distributions corresponding to points on interaction diagram.

(a) If the stability index, Q , for a story is less than 0.04, where

$$Q = \frac{\sum P_u \Delta_u}{H_u h_s} \leq 0.04 \quad (4.46)$$

(b) If the sum of the lateral stiffness of the bracing elements in a story exceeds six times the lateral stiffness of all the columns in the story.

4. *Radius of gyration.* For a rectangular cross-section r equals $0.3 h$, and for a circular cross-section r equals $0.25 h$. For other sections, r equals $\sqrt{I/A}$.
5. *Consideration of slenderness effects.* ACI 10.11.4.1 allows slenderness effects to be neglected for columns in braced frames when

$$\frac{kl_u}{r} < 34 - 12 \frac{M_{1b}}{M_{2b}} \quad (4.47)$$

ACI 10.11.4.2 allows slenderness effects to be neglected for columns in unbraced frames when

$$\frac{kl_u}{r} < 22 \quad (4.48)$$

If kl_u/r exceeds 100, ACI 10.11.4.3 states that design shall be based on second-order analysis.

6. *Minimum moments.* For columns in a braced frame, M_{2b} shall be not less than the value given in ACI 10.11.5.4. In an unbraced frame ACI 10.11.5.5 applies for M_{2s} .
7. *Moment magnifier equation.* ACI 10.11.5.1 states that columns shall be designed for the factored axial load, P_u , and a magnified factored moment, M_c , defined by

$$M_c = \delta_b M_{2b} + \delta_s M_{2s} \quad (4.49)$$

where M_{2b} is the larger factored end moment acting on the column due to loads causing no appreciable sidesway (lateral deflections less than $l/1500$) and M_{2s} is the larger factored end moment due to loads that result in an appreciable sidesway. The moments are computed from a conventional first-order elastic frame analysis. For the above equation, the following apply:

$$\begin{aligned} \delta_b &= \frac{C_m}{1 - P_u/\phi P_c} \geq 1.0 \\ \delta_s &= \frac{1}{1 - \sum P_u/\phi \sum P_c} \geq 1.0 \end{aligned} \quad (4.50)$$

For members braced against sidesway, ACI 10.11.5.1 gives $\delta_s = 1.0$.

$$C_m = 0.6 + 0.4 \frac{M_{1b}}{M_{2b}} \geq 0.4 \quad (4.51)$$

The ratio M_{1b}/M_{2b} is taken as positive if the member is bent in single curvature and negative if the member is bent in double curvature. Equation 4.51 applies only to columns in braced frames. In all other cases, ACI 10.11.5.3 states that $C_m = 1.0$.

$$P_c = \frac{\pi^2 EI}{(kl_u)^2} \quad (4.52)$$

where

$$EI = \frac{E_c I_g / 5 + E_s I_{se}}{1 + \beta_d} \quad (4.53)$$

or, approximately

$$EI = \frac{E_c I_g / 2.5}{1 + \beta_d} \quad (4.54)$$

When computing δ_b ,

$$\beta_d = \frac{\text{Axial load due to factored dead load}}{\text{Total factored axial load}} \quad (4.55)$$

When computing δ_s ,

$$\beta_d = \frac{\text{Factored sustained lateral shear in the story}}{\text{Total factored lateral shear in the story}} \quad (4.56)$$

If δ_b or δ_s is found to be negative, the column should be enlarged. If either δ_b or δ_s exceeds 2.0, consideration should be given to enlarging the column.

4.4.4 Columns under Axial Load and Biaxial Bending

The nominal **ultimate strength** of a section under biaxial bending and compression is a function of three variables, P_n , M_{nx} , and M_{ny} , which may also be expressed as P_n acting at eccentricities $e_y = M_{nx}/P_n$ and $e_x = M_{ny}/P_n$ with respect to the x and y axes. Three types of failure surfaces can be defined. In the first type, S_1 , the three orthogonal axes are defined by P_n , e_x , and e_y ; in the second type, S_2 , the variables defining the axes are $1/P_n$, e_x , and e_y ; and in the third type, S_3 the axes are P_n , M_{nx} , and M_{ny} . In the presentation that follows, the Bresler reciprocal load method makes use of the reciprocal failure surface S_2 , and the Bresler load contour method and the PCA load contour method both use the failure surface S_3 .

Bresler Reciprocal Load Method

Using a failure surface of type S_2 , Bresler proposed the following equation as a means of approximating a point on the failure surface corresponding to prespecified eccentricities e_x and e_y :

$$\frac{1}{P_{ni}} = \frac{1}{P_{nx}} + \frac{1}{P_{ny}} - \frac{1}{P_0} \quad (4.57)$$

where

P_{ni} = nominal axial load strength at given eccentricity along both axes

P_{nx} = nominal axial load strength at given eccentricity along x axis

P_{ny} = nominal axial load strength at given eccentricity along y axis

P_0 = nominal axial load strength for pure compression (zero eccentricity)

Test results indicate that Equation 4.57 may be inappropriate when small values of axial load are involved, such as when P_n/P_0 is in the range of 0.06 or less. For such cases the member should be designed for flexure only.

Bresler Load Contour Method

The failure surface S_3 can be thought of as a family of curves (load contours) each corresponding to a constant value of P_n . The general nondimensional equation for the load contour at constant P_n may be expressed in the following form:

$$\left(\frac{M_{nx}}{M_{ox}}\right)^{\alpha_1} + \left(\frac{M_{ny}}{M_{oy}}\right)^{\alpha_2} = 1.0 \quad (4.58)$$

where

$M_{nx} = P_n e_y$; $M_{ny} = P_n e_x$

$M_{ox} = M_{nx}$ capacity at axial load P_n when M_{ny} (or e_x) is zero

$M_{oy} = M_{ny}$ capacity at axial load P_n when M_{nx} (or e_y) is zero

The exponents α_1 and α_2 depend on the column dimensions, amount and arrangement of the reinforcement, and material strengths. Bresler suggests taking $\alpha_1 = \alpha_2 = \alpha$. Calculated values of α vary from 1.15 to 1.55. For practical purposes, α can be taken as 1.5 for rectangular sections and between 1.5 and 2.0 for square sections.

PCA (Parme-Gowens) Load Contour Method

This method has been developed as an extension of the Bresler load contour method in which the Bresler interaction Equation 4.58 is taken as the basic strength criterion. In this approach, a point on the load contour is defined in such a way that the biaxial moment strengths M_{nx} and M_{ny} are in the same ratio as the uniaxial moment strengths M_{ox} and M_{oy} ,

$$\frac{M_{ny}}{M_{nx}} = \frac{M_{oy}}{M_{ox}} = \beta \quad (4.59)$$

The actual value of β depends on the ratio of P_n to P_0 as well as the material and cross-sectional properties, with the usual range of values between 0.55 and 0.70. Charts for determining β can be found in ACI Publication SP-17A(85), *A Design Handbook for Columns* [2].

Substituting Equation 4.59 into Equation 4.58,

$$\begin{aligned} \left(\frac{\beta M_{ox}}{M_{ox}}\right)^\alpha + \left(\frac{\beta M_{oy}}{M_{oy}}\right)^\alpha &= 1 \\ 2\beta^\alpha &= 1 \\ \beta^\alpha &= 1/2 \\ \alpha &= \frac{\log 0.5}{\log \beta} \end{aligned} \quad (4.60)$$

thus,

$$\left(\frac{M_{nx}}{M_{ox}}\right)^{\log 0.5 / \log \beta} + \left(\frac{M_{ny}}{M_{oy}}\right)^{\log 0.5 / \log \beta} = 1 \quad (4.61)$$

For more information on columns subjected to biaxial bending, see *Reinforced Concrete Design* by Chu-Kia Wang and Charles G. Salmon [11].

4.5 Shear and Torsion

4.5.1 Reinforced Concrete Beams and One-Way Slabs Strength Design

The cracks that form in a reinforced concrete beam can be due to flexure or a combination of flexure and shear. Flexural cracks start at the bottom of the beam, where the flexural stresses are the largest. Inclined cracks, also called *shear cracks* or *diagonal tension cracks*, are due to a combination of flexure and shear. Inclined cracks must exist before a shear failure can occur.

Inclined cracks form in two different ways. In thin-walled I-beams in which the shear stresses in the web are high while the flexural stresses are low, a web-shear crack occurs. The inclined cracking shear can be calculated as the shear necessary to cause a principal tensile stress equal to the tensile strength of the concrete at the centroid of the beam.

In most reinforced concrete beams, however, flexural cracks occur first and extend vertically in the beam. These alter the state of stress in the beam and cause a stress concentration near the tip of the crack. In time, the flexural cracks extend to become flexure-shear cracks. Empirical equations have

been developed to calculate the flexure-shear cracking load, since this cracking cannot be predicted by calculating the principal stresses.

In the ACI Code, the basic design equation for the shear capacity of concrete beams is as follows:

$$V_u \leq \phi V_n \quad (4.62)$$

where V_u is the shear force due to the factored loads, ϕ is the **strength reduction factor** equal to 0.85 for shear, and V_n is the nominal shear resistance, which is given by

$$V_n = V_c + V_s \quad (4.63)$$

where V_c is the shear carried by the concrete and V_s is the shear carried by the shear reinforcement.

The torsional capacity of a beam as given in ACI 11.6.5 is as follows:

$$T_u \leq \phi T_n \quad (4.64)$$

where T_u is the torsional moment due to factored loads, ϕ is the strength reduction factor equal to 0.85 for torsion, and T_n is the nominal torsional moment strength given by

$$T_n = T_c + T_s \quad (4.65)$$

where T_c is the torsional moment strength provided by the concrete and T_s is the torsional moment strength provided by the torsion reinforcement.

Design of Beams and One-Way Slabs Without Shear Reinforcement: for Shear

The critical section for shear in reinforced concrete beams is taken at a distance d from the face of the support. Sections located at a distance less than d from the support are designed for the shear computed at d .

Shear Strength Provided by Concrete Beams without web reinforcement will fail when inclined cracking occurs or shortly afterwards. For this reason the shear capacity is taken equal to the inclined cracking shear. ACI gives the following equations for calculating the shear strength provided by the concrete for beams without web reinforcement subject to shear and flexure:

$$V_c = 2\sqrt{f'_c}b_wd \quad (4.66)$$

or, with a more detailed equation:

$$V_c = \left(1.9\sqrt{f'_c} + 2500\rho_w \frac{V_u d}{M_u} \right) b_wd \leq 3.5\sqrt{f'_c}b_wd \quad (4.67)$$

The quantity $V_u d / M_u$ is not to be taken greater than 1.0 in computing V_c where M_u is the factored moment occurring simultaneously with V_u at the section considered.

Combined Shear, Moment, and Axial Load For members that are also subject to axial compression, ACI modifies Equation 4.66 as follows (ACI 11.3.1.2):

$$V_c = 2 \left(1 + \frac{N_u}{2000A_k} \right) \sqrt{f'_c}b_wd \quad (4.68)$$

where N_u is positive in compression. ACI 11.3.2.2 contains a more detailed calculation for the shear strength of members subject to axial compression.

For members subject to axial tension, ACI 11.3.1.3 states that shear reinforcement shall be designed to carry total shear. As an alternative, ACI 11.3.2.3 gives the following for the shear strength of members subject to axial tension:

$$V_c = 2 \left(1 - \frac{N_u}{500A_g} \right) \sqrt{f'_c}b_wd \quad (4.69)$$

where N_u is negative in tension. In Equation 4.68 and 4.69 the terms $\sqrt{f'_c}$, N_u/A_g , 2000, and 500 all have units of psi.

Combined Shear, Moment, and Torsion For members subject to torsion, ACI 11.3.1.4 gives the equation for the shear strength of the concrete as the following:

$$V_c = \frac{2\sqrt{f'_c}b_wd}{\sqrt{1 + (2.5C_tT_u/V_u)^2}} \quad (4.70)$$

where

$$T_u \geq \phi \left(0.5\sqrt{f'_c} \sum x^2y \right)$$

Design of Beams and One-Way Slabs Without Shear Reinforcements: for Torsion

ACI 11.6.1 requires that torsional moments be considered in design if

$$T_u \geq \phi \left(0.5\sqrt{f'_c} \sum x^2y \right) \quad (4.71)$$

Otherwise, torsion effects may be neglected.

The critical section for torsion is taken at a distance d from the face of support, and sections located at a distance less than d are designed for the torsion at d . If a concentrated torque occurs within this distance, the critical section is taken at the face of the support.

Torsional Strength Provided by Concrete Torsion seldom occurs by itself; bending moments and shearing forces are typically present also. In an uncracked member, shear forces as well as torques produce shear stresses. Flexural shear forces and torques interact in a way that reduces the strength of the member compared with what it would be if shear or torsion were acting alone. The interaction between shear and torsion is taken into account by the use of a circular interaction equation. For more information, refer to *Reinforced Concrete Mechanics and Design* by James G. MacGregor [8].

The torsional moment strength provided by the concrete is given in ACI 11.6.6.1 as

$$T_c = \frac{0.8\sqrt{f'_c}x^2y}{\sqrt{1 + (0.4V_u/C_tT_u)^2}} \quad (4.72)$$

Combined Torsion and Axial Load For members subject to significant axial tension, ACI 11.6.6.2 states that the torsion reinforcement must be designed to carry the total torsional moment, or as an alternative modify T_c as follows:

$$T_c = \frac{0.8\sqrt{f'_c}x^2y}{\sqrt{1 + (0.4V_u/C_tT_u)^2}} \left(1 + \frac{N_u}{500A_g} \right) \quad (4.73)$$

where N_u is negative for tension.

Design of Beams and One-Way Slabs without Shear Reinforcement:

Minimum Reinforcement ACI 11.5.5.1 requires a minimum amount of web reinforcement to be provided for shear and torsion if the factored shear force V_u exceeds one half the shear strength provided by the concrete ($V_u \geq 0.5\phi V_c$) except in the following:

- (a) Slabs and footings
- (b) Concrete joist construction

- (c) Beams with total depth not greater than 10 inches, 2 1/2 times the thickness of the flange, or 1/2 the width of the web, whichever is greatest

The minimum area of shear reinforcement shall be at least

$$A_{v(\min)} = \frac{50b_ws}{f_y} \text{ for } T_u < \phi \left(0.5\sqrt{f'_c} \sum x^2y \right) \quad (4.74)$$

When torsion is to be considered in design, the sum of the closed stirrups for shear and torsion must satisfy the following:

$$A_v + 2A_t \geq \frac{50b_ws}{f_y} \quad (4.75)$$

where A_v is the area of two legs of a closed stirrup and A_t is the area of only one leg of a closed stirrup.

Design of Stirrup Reinforcement for Shear and Torsion

Shear Reinforcement Shear reinforcement is to be provided when $V_u \geq \phi V_c$, such that

$$V_s \geq \frac{V_u}{\phi} - V_c \quad (4.76)$$

The design yield strength of the shear reinforcement is not to exceed 60,000 psi.

When the shear reinforcement is perpendicular to the axis of the member, the shear resisted by the stirrups is

$$V_s = \frac{A_v f_y d}{s} \quad (4.77)$$

If the shear reinforcement is inclined at an angle α , the shear resisted by the stirrups is

$$V_s = \frac{A_v f_y (\sin \alpha + \cos \alpha) d}{s} \quad (4.78)$$

The maximum shear strength of the shear reinforcement is not to exceed $8\sqrt{f'_c}b_wd$ as stated in ACI 11.5.6.8.

Spacing Limitations for Shear Reinforcement ACI 11.5.4.1 sets the maximum spacing of vertical stirrups as the smaller of $d/2$ or 24 inches. The maximum spacing of inclined stirrups is such that a 45° line extending from midheight of the member to the tension reinforcement will intercept at least one stirrup.

If V_s exceeds $4\sqrt{f'_c}b_wd$, the maximum allowable spacings are reduced to one half of those just described.

Torsion Reinforcement Torsion reinforcement is to be provided when $T_u \geq \phi T_c$, such that

$$T_s \geq \frac{T_u}{\phi} - T_c \quad (4.79)$$

The design yield strength of the torsional reinforcement is not to exceed 60,000 psi.

The torsional moment strength of the reinforcement is computed by

$$T_s = \frac{A_t \alpha_t x_1 y_1 f_y}{s} \quad (4.80)$$

where

$$\alpha_t = [0.66 + 0.33 (y_t/x_t)] \geq 1.50 \quad (4.81)$$

where A_t is the area of one leg of a closed stirrup resisting torsion within a distance s . The torsional moment strength is not to exceed $4 T_c$ as given in ACI 11.6.9.4.

Longitudinal reinforcement is to be provided to resist axial tension that develops as a result of the torsional moment (ACI 11.6.9.3). The required area of longitudinal bars distributed around the perimeter of the closed stirrups that are provided as torsion reinforcement is to be

$$A_l \geq 2A_t \frac{(x_1 + y_1)}{s}$$

$$A_l \geq \left[\frac{400xs}{f_y} \left(\frac{T_u}{T_u + \frac{V_u}{3C_t}} \right) = 2A_t \right] \left(\frac{x_1 + y_1}{s} \right) \quad (4.82)$$

Spacing Limitations for Torsion Reinforcement ACI 11.6.8.1 gives the maximum spacing of closed stirrups as the smaller of $(x_1 + y_1)/4$ or 12 inches.

The longitudinal bars are to be spaced around the circumference of the closed stirrups at not more than 12 inches apart. At least one longitudinal bar is to be placed in each corner of the closed stirrups (ACI 11.6.8.2).

Design of Deep Beams

ACI 11.8 covers the shear design of deep beams. This section applies to members with $l_n/d < 5$ that are loaded on one face and supported on the opposite face so that compression struts can develop between the loads and the supports. For more information on deep beams, see *Reinforced Concrete Mechanics and Design*, 2nd ed. by James G. MacGregor [8].

The basic design equation for simple spans deep beams is

$$V_u \leq \phi (V_c + V_s) \quad (4.83)$$

where V_c is the shear carried by the concrete and V_s is the shear carried by the vertical and horizontal web reinforcement.

The shear strength of deep beams shall not be taken greater than

$$V_n = 8\sqrt{f'_c}b_wd \text{ for } l_n/d < 2$$

$$V_n = \frac{2}{3} \left(10 + \frac{l_n}{d} \right) \sqrt{f'_c}b_wd \text{ for } 2 \leq l_n/d \leq 5 \quad (4.84)$$

Design for shear is done at a critical section located at $0.15 l_n$ from the face of support in uniformly loaded beams, and at the middle of the [shear span](#) for beams with concentrated loads. For both cases, the critical section shall not be farther than d from the face of the support. The shear reinforcement required at this critical section is to be used throughout the span.

The shear carried by the concrete is given by

$$V_c = 2\sqrt{f'_c}b_wd \quad (4.85)$$

or, with a more detailed calculation,

$$V_c = \left(3.5 - 2.5 \frac{M_u}{V_u d} \right) \left(1.9\sqrt{f'_c} + 2500\rho_w \frac{V_u d}{M_u} \right) b_wd \leq 6\sqrt{f'_c}b_wd \quad (4.86)$$

where

$$\left(3.5 - 2.5 \frac{M_u}{V_u d} \right) \leq 2.5 \quad (4.87)$$

In Equations 4.86 and 4.87 M_u and V_u are the factored moment and shear at the critical section.

Shear reinforcement is to be provided when $V_u \geq \phi V_c$ such that

$$V_s = \frac{V_u}{\phi} - V_c \quad (4.88)$$

where

$$V_s = \left[\frac{A_v}{s} \left(\frac{1 + l_n/d}{12} \right) + \frac{A_{vh}}{s_2} \left(\frac{11 - l_n/d}{12} \right) \right] f_y d \quad (4.89)$$

where A_v and s are the area and spacing of the vertical shear reinforcement and A_{vh} and s_2 refer to the horizontal shear reinforcement.

ACI 11.8.9 and 11.8.10 require minimum reinforcement in both the vertical and horizontal sections as follows:

(a) vertical direction

$$A_v \geq 0.0015b_w s \quad (4.90)$$

where

$$s \leq \left\{ \begin{array}{l} d/5 \\ 18 \text{ in.} \end{array} \right\} \quad (4.91)$$

(b) horizontal direction

$$A_{vh} \geq 0.0025b_w s_2 \quad (4.92)$$

where

$$s_2 \leq \left\{ \begin{array}{l} d/3 \\ 18 \text{ in.} \end{array} \right\} \quad (4.93)$$

4.5.2 Prestressed Concrete Beams and One-Way Slabs Strength Design

At loads near failure, a prestressed beam is usually heavily cracked and behaves similarly to an ordinary reinforced concrete beam. Many of the equations developed previously for design of web reinforcement for nonprestressed beams can also be applied to prestressed beams.

Shear design is based on the same basic equation as before,

$$V_u \leq \phi (V_c + V_s)$$

where $\phi = 0.85$.

The critical section for shear is taken at a distance $h/2$ from the face of the support. Sections located at a distance less than $h/2$ are designed for the shear computed at $h/2$.

Shear Strength Provided by the Concrete

The shear force resisted by the concrete after cracking has occurred is taken as equal to the shear that caused the first **diagonal crack**. Two types of diagonal cracks have been observed in tests of prestressed concrete.

1. Flexure-shear cracks, occurring at nominal shear V_{ci} , start as nearly vertical flexural cracks at the tension face of the beam, then spread diagonally upward toward the compression face.
2. Web shear cracks, occurring at nominal shear V_{cw} , start in the web due to high diagonal tension, then spread diagonally both upward and downward.

The shear strength provided by the concrete for members with effective prestress force not less than 40% of the tensile strength of the flexural reinforcement is

$$V_c = \left(0.6\sqrt{f'_c} + 700\frac{V_u d}{M_u} \right) b_w d \leq 2\sqrt{f'_c} b_w d \quad (4.94)$$

V_c may also be computed as the lesser of V_{ci} and V_{cw} , where

$$V_{ci} = 0.6\sqrt{f'_c} b_w d + V_d + \frac{V_i M_{cr}}{M_{\max}} \geq 1.7\sqrt{f'_c} b_w d \quad (4.95)$$

$$M_{cr} = \left(\frac{I}{y_t} \right) (6\sqrt{f'_c} + f_{pc} - f_d) \quad (4.96)$$

$$V_{cw} = (3.5\sqrt{f'_c} + 0.3f_{pc}) b_w d + V_p \quad (4.97)$$

In Equations 4.95 and 4.97 d is the distance from the extreme compression fiber to the centroid of the prestressing steel or $0.8h$, whichever is greater.

Shear Strength Provided by the Shear Reinforcement

Shear reinforcement for prestressed concrete is designed in a similar manner as for reinforced concrete, with the following modifications for minimum amount and spacing.

Minimum Reinforcement The minimum area of shear reinforcement shall be at least

$$A_{v(\min)} = \frac{50b_w s}{f_y} \text{ for } T_u < \phi \left(0.5\sqrt{f'_c} \sum x^2 y \right) \quad (4.98)$$

or

$$A_{v(\min)} = \frac{A_{ps} f_{pu} s}{80 f_y d} \sqrt{\frac{d}{b_w}} \quad (4.99)$$

Spacing Limitations for Shear Reinforcement ACI 11.5.4.1 sets the maximum spacing of vertical stirrups as the smaller of $(3/4)h$ or 24 in. The maximum spacing of inclined stirrups is such that a 45° line extending from midheight of the member to the tension reinforcement will intercept at least one stirrup.

If V_s exceeds $4\sqrt{f'_c} b_w d$, the maximum allowable spacings are reduced to one-half of those just described.

4.6 Development of Reinforcement

The **development length**, l_d , is the shortest length of bar in which the bar stress can increase from zero to the yield strength, f_y . If the distance from a point where the bar stress equals f_y to the end of the bar is less than the development length, the bar will pull out of the concrete. Development lengths are different for tension and compression.

4.6.1 Development of Bars in Tension

ACI Fig. R12.2 gives a flow chart for determining development length. The steps are outlined below.

The basic tension development lengths have been found to be (ACI 12.2.2). For no. 11 and smaller bars and deformed wire:

$$l_{db} = \frac{0.04 A_b f_y}{\sqrt{f'_c}} \quad (4.100)$$

For no. 14 bars:

$$l_{db} = \frac{0.085 f_y}{\sqrt{f'_c}} \quad (4.101)$$

For no. 18 bars:

$$l_{db} = \frac{0.125 f_y}{\sqrt{f'_c}} \quad (4.102)$$

where $\sqrt{f'_c}$ is not to be taken greater than 100 psi.

The development length, l_d , is computed as the product of the basic development length and modification factors given in ACI 12.2.3, 12.2.4, and 12.2.5. The development length obtained from ACI 12.2.2 and 12.2.3.1 through 12.2.3.5 shall not be less than

$$\frac{0.03 d_b f_y}{\sqrt{f'_c}} \quad (4.103)$$

as given ACI 12.2.3.6.

The length computed from ACI 12.2.2 and 12.2.3 is then multiplied by factors given in ACI 12.2.4 and 12.2.5. The factors given in ACI 12.2.3.1 through 12.2.3.3 and 12.2.4 are required, but the factors in ACI 12.2.3.4, 12.2.3.5, and 12.2.5 are optional.

The development length is not to be less than 12 inches (ACI 12.2.1).

4.6.2 Development of Bars in Compression

The basic compression development length is (ACI 12.3.2)

$$l_{db} = \frac{0.02 d_b f_y}{\sqrt{f'_c}} \geq 0.003 d_b f_y \quad (4.104)$$

The development length, l_d , is found as the product of the basic development length and applicable modification factors given in ACI 12.3.3.

The development length is not to be less than 8 inches (ACI 12.3.1).

4.6.3 Development of Hooks in Tension

The basic development length for a hooked bar with $f_y = 60,000$ psi is (ACI 12.5.2)

$$l_{db} = \frac{1200 d_b}{\sqrt{f'_c}} \quad (4.105)$$

The development length, l_{dh} , is found as the product of the basic development length and applicable modification factors given in ACI 12.5.3.

The development length of the hook is not to be less than 8 bar diameters or 6 inches (ACI 12.5.1).

Hooks are not to be used to develop bars in compression.

4.6.4 Splices, Bundled Bars, and Web Reinforcement

Splices

Tension Lap Splices ACI 12.15 distinguishes between two types of tension lap splices depending on the amount of reinforcement provided and the fraction of the bars spliced in a given length—see ACI Table R12.15.2. The splice lengths for each splice class are as follows:

Class A splice: $1.0 l_d$

Class B splice: $1.3 l_d$

where l_d is the tensile development length as computed in ACI 12.2 without the modification factor for excess reinforcement given in ACI 12.2.5. The minimum splice length is 12 inches.

Lap splices are not to be used for bars larger than no. 11 except at footing to column joints and for compression lap splices of no. 14 and no. 18 bars with smaller bars (ACI 12.14.2.1). The center-to-center distance between two bars in a lap splice cannot be greater than one-fifth the required lap splice length with a maximum of 6 inches (ACI 12.14.2.3). ACI 21.3.2.3 requires that tension lap splices of flexural reinforcement in beams resisting seismic loads be enclosed by **hoops** or spirals.

Compression Lap Splices The splice length for a compression lap splice is given in ACI 12.16.1 as

$$l_s = 0.0005 f_y d_b \text{ for } f_y \leq 60,000 \text{ psi} \quad (4.106)$$

$$l_s = (0.0009 f_y - 24) d_b \text{ for } f_y > 60,000 \text{ psi} \quad (4.107)$$

but not less than 12 inches. For f'_c less than 3000 psi, the lap length must be increased by one-third.

When different size bars are lap spliced in compression, the splice length is to be the larger of:

1. Compression splice length of the smaller bar, or
2. Compression development length of larger bar.

Compression lap splices are allowed for no. 14 and no. 18 bars to no. 11 or smaller bars (ACI 12.16.2).

End-Bearing Splices End-bearing splices are allowed for compression only where the compressive stress is transmitted by bearing of square cut ends held in concentric contact by a suitable device. According to ACI 12.16.4.2 bar ends must terminate in flat surfaces within $1\ 1/2^\circ$ of right angles to the axis of the bars and be fitted within 3° of full bearing after assembly. End-bearing splices are only allowed in members containing closed ties, closed stirrups, or spirals.

Welded Splices or Mechanical Connections Bars stressed in tension or compression may be spliced by welding or by various mechanical connections. ACI 12.14.3, 12.15.3, 12.15.4, and 12.16.3 govern the use of such splices. For further information see *Reinforced Concrete Design*, by Chu-Kia Wang and Charles G. Salmon [11].

Bundled Bars

The requirements of ACI 12.4.1 specify that the development length for bundled bars be based on that for the individual bar in the bundle, increased by 20% for a three-bar bundle and 33% for a four-bar bundle. ACI 12.4.2 states that "a unit of bundled bars shall be treated as a single bar of a diameter derived from the equivalent total area" when determining the appropriate modification factors in ACI 12.2.3 and 12.2.4.3.

Web Reinforcement

ACI 12.13.1 requires that the web reinforcement be as close to the compression and tension faces as cover and bar-spacing requirements permit. The ACI Code requirements for stirrup anchorage are illustrated in Figure 4.4.

- (a) ACI 12.13.3 requires that each bend away from the ends of a stirrup enclose a longitudinal bar, as seen in Figure 4.4(a).

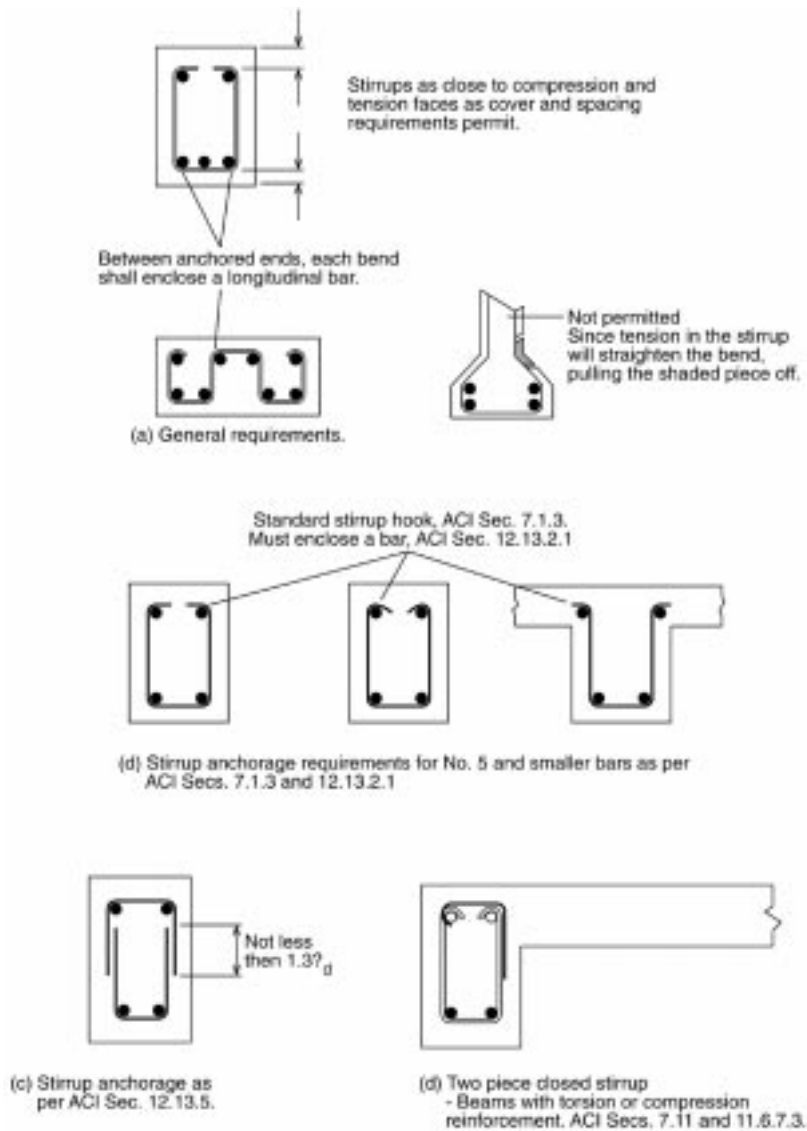

FIGURE 4.4: Stirrup detailing requirements.

- (b) For no. 5 or D31 wire stirrups and smaller with any yield strength and for no. 6, 7, and 8 bars with a yield strength of 40,000 psi or less, ACI 12.13.2.1 allows the use of a standard hook around longitudinal reinforcement, as shown in Figure 4.4(b).
- (c) For no. 6, 7, and 8 stirrups with f_y greater than 40,000 psi, ACI 12.13.2.2 requires a standard hook around a longitudinal bar plus an embedment between midheight of the member and the outside end of the hook of at least $0.014 d_b f_y / \sqrt{f'_c}$.
- (d) Requirements for welded wire fabric forming U stirrups are given in ACI 12.13.2.3.

- (e) Pairs of U stirrups that form a closed unit shall have a lap length of $1.3l_d$ as shown in Figure 4.4(c). This type of stirrup has proven unsuitable in seismic areas.
- (f) Requirements for longitudinal bars bent to act as shear reinforcement are given in ACI 12.13.4.

4.7 Two-Way Systems

4.7.1 Definition

When the ratio of the longer to the shorter spans of a floor panel drops below 2, the contribution of the longer span in carrying the floor load becomes substantial. Since the floor transmits loads in two directions, it is defined as a *two-way system*, and flexural reinforcement is designed for both directions. Two-way systems include *flat plates*, *flat slabs*, *two-way slabs*, and *waffle slabs* (see Figure 4.5). The choice between these different types of two-way systems is largely a matter of the architectural layout, magnitude of the design loads, and span lengths. A flat plate is simply a slab of uniform thickness supported directly on columns, generally suitable for relatively light loads. For larger loads and spans, a flat slab becomes more suitable with the column capitals and *drop panels* providing higher shear and flexural strength. A slab supported on beams on all sides of each floor panel is generally referred to as a two-way slab. A waffle slab is equivalent to a two-way joist system or may be visualized as a solid slab with recesses in order to decrease the weight of the slab.

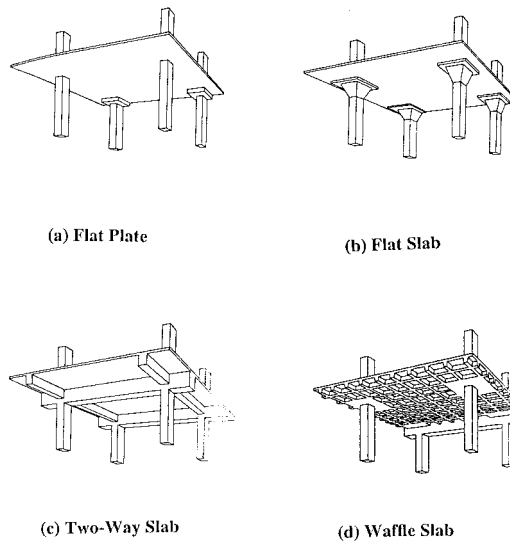

FIGURE 4.5: Two-way systems.

4.7.2 Design Procedures

The ACI code [1] states that a two-way slab system “may be designed by any procedure satisfying conditions of equilibrium and geometric compatibility if shown that the design strength at every section is at least equal to the required strength . . . and that all serviceability conditions, including

specified limits on deflections, are met” (p.204). There are a number of possible approaches to the analysis and design of two-way systems based on elastic theory, [limit analysis](#), finite element analysis, or combination of elastic theory and limit analysis. The designer is permitted by the ACI Code to adopt any of these approaches provided that all safety and serviceability criteria are satisfied. In general, only for cases of a complex two-way system or unusual loading would a finite element analysis be chosen as the design approach. Otherwise, more practical design approaches are preferred. The ACI Code details two procedures—the *direct design method* and the *equivalent frame method*—for the design of floor systems with or without beams. These procedures were derived from analytical studies based on elastic theory in conjunction with aspects of limit analysis and results of experimental tests. The primary difference between the direct design method and equivalent frame method is in the way moments are computed for two-way systems.

The *yield-line theory* is a limit analysis method devised for slab design. Compared to elastic theory, the yield-line theory gives a more realistic representation of the behavior of slabs at the ultimate limit state, and its application is particularly advantageous for irregular column spacing. While the yield-line method is an upper-bound [limit design](#) procedure, *strip method* is considered to give a lower-bound design solution. The strip method offers a wide latitude of design choices and it is easy to use; these are often cited as the appealing features of the method.

Some of the earlier design methods based on moment coefficients from elastic analysis are still favored by many designers. These methods are easy to apply and give valuable insight into slab behavior; their use is especially justified for many irregular slab cases where the preconditions of the direct design method are not met or when column interaction is not significant. Table 4.7 lists the moment coefficients taken from method 2 of the 1963 ACI Code.

TABLE 4.7 Elastic Moment Coefficients for Two-Way Slabs

Moments	Short span						Long span, all span ratios
	Span ratio, short/long						
	1.0	0.9	0.8	0.7	0.6	0.5 and less	
Case 1—Interior panels							
Negative moment at:							
Continuous edge	0.033	0.040	0.048	0.055	0.063	0.083	0.033
Discontinuous edge	—	—	—	—	—	—	—
Positive moment at midspan	0.025	0.030	0.036	0.041	0.047	0.062	0.025
Case 2—One edge discontinuous							
Negative moment at:							
Continuous edge	0.041	0.048	0.055	0.062	0.069	0.085	0.041
Discontinuous edge	0.021	0.024	0.027	0.031	0.035	0.042	0.021
Positive moment at midspan	0.031	0.036	0.041	0.047	0.052	0.064	0.031
Case 3—Two edges discontinuous							
Negative moment at:							
Continuous edge	0.049	0.057	0.064	0.071	0.078	0.090	0.049
Discontinuous edge	0.025	0.028	0.032	0.036	0.039	0.045	0.025
Positive moment at midspan:	0.037	0.043	0.048	0.054	0.059	0.068	0.037
Case 4—Three edges discontinuous							
Negative moment at:							
Continuous edge	0.058	0.066	0.074	0.082	0.090	0.098	0.058
Discontinuous edge	0.029	0.033	0.037	0.041	0.045	0.049	0.029
Positive moment at midspan:	0.044	0.050	0.056	0.062	0.068	0.074	0.044
Case 5—Four edges discontinuous							
Negative moment at:							
Continuous edge	—	—	—	—	—	—	—
Discontinuous edge	0.033	0.038	0.043	0.047	0.053	0.055	0.033
Positive moment at midspan	0.050	0.057	0.064	0.072	0.080	0.083	0.050

As in the 1989 code, two-way slabs are divided into [column strips](#) and middle strips as indicated by Figure 4.6, where l_1 and l_2 are the center-to-center span lengths of the floor panel. A column strip is

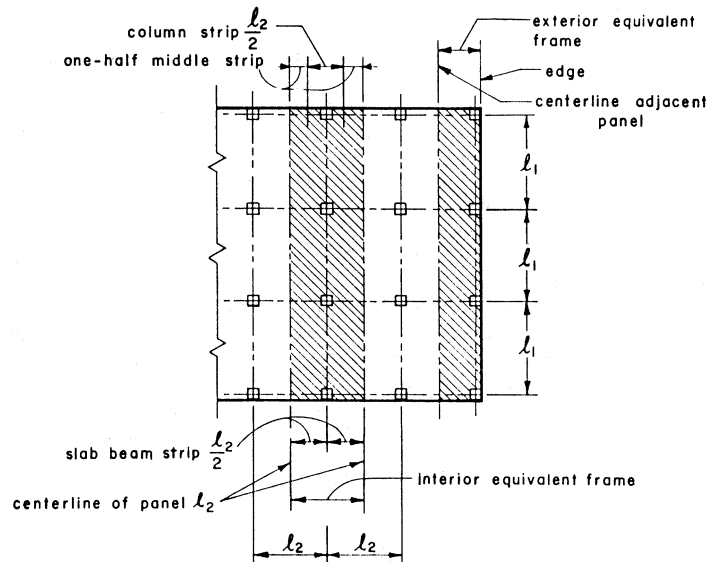

FIGURE 4.6: Definitions of equivalent frame, column strip, and middle strip. (From ACI Committee 318. 1992. *Building Code Requirements for Reinforced Concrete and Commentary, ACI 318-89 (Revised 92) and ACI 318R-89 (Revised 92)*, Detroit, MI. With permission.)

a design strip with a width on each side of a column centerline equal to $0.25l_2$ or $0.25l_1$, whichever is less. A middle strip is a design strip bounded by two column strips. Taking the moment coefficients from Table 4.7, bending moments per unit width M for the middle strips are computed from the formula

$$M = (\text{Coef.})wl_s^2 \quad (4.108)$$

where w is the total uniform load per unit area and l_s is the shorter span length of l_1 and l_2 . The average moments per unit width in the column strip is taken as two-thirds of the corresponding moments in the middle strip.

4.7.3 Minimum Slab Thickness and Reinforcement

ACI Code Section 9.5.3 contains requirements to determine minimum slab thickness of a two-way system for deflection control. For slabs without beams, the thickness limits are summarized by Table 4.8, but thickness must not be less than 5 in. for slabs without drop panels or 4 in. for slabs with drop panels. In Table 4.8 l_n is the length of clear span in the long direction and α is the ratio of flexural stiffness of beam section to flexural stiffness of a width of slab bounded laterally by centerline of adjacent panel on each side of beam.

For slabs with beams, it is necessary to compute the minimum thickness h from

$$h = \frac{l_n \left(0.8 + \frac{f_y}{200,000} \right)}{36 + 5\beta \left[\alpha_m - 0.12 \left(1 + \frac{1}{\beta} \right) \right]} \quad (4.109)$$

but not less than

$$h = \frac{l_n \left(0.8 + \frac{f_y}{200,000} \right)}{36 + 9\beta} \quad (4.110)$$

and need not be more than

$$h = \frac{l_n \left(0.8 + \frac{f_y}{200,000} \right)}{36} \quad (4.111)$$

where β is the ratio of clear spans in long-to-short direction and α_m is the average value of α for all beams on edges of a panel. In no case should the slab thickness be less than 5 in. for $\alpha_m < 2.0$ or less than 3 1/2 in. for $\alpha_m \geq 2.0$.

Minimum reinforcement in two-way slabs is governed by shrinkage and temperature controls to minimize cracking. The minimum reinforcement area stipulated by the ACI Code shall not be less than 0.0018 times the gross concrete area when grade 60 steel is used (0.0020 when grade 40 or grade 50 is used). The spacing of reinforcement in two-way slabs shall exceed neither two times the slab thickness nor 18 in.

TABLE 4.8 Minimum Thickness of Two-Way Slabs without Beams

Yield stress f_y , psi ^a	Exterior panels		Interior panels
	Without edge beams	With edge beams ^b	
Without drop panels			
40,000	$l_n/33$	$l_n/36$	$l_n/36$
60,000	$l_n/30$	$l_n/33$	$l_n/33$
With drop panels			
40,000	$l_n/36$	$l_n/40$	$l_n/40$
60,000	$l_n/33$	$l_n/36$	$l_n/36$

^a For values of reinforcement yield stress between 40,000 and 60,000 psi minimum thickness shall be obtained by linear interpolation.

^b Slabs with beams between columns along exterior edges. The value of α for the edge beam shall not be less than 0.8.

From ACI Committee 318. 1992. *Building Code Requirements for Reinforced Concrete and Commentary, ACI 318-89 (Revised 92) and ACI 318R-89 (Revised 92)*, Detroit, MI. With permission.

4.7.4 Direct Design Method

The direct design method consists of a set of rules for the design of two-ways slabs with or without beams. Since the method was developed assuming simple designs and construction, its application is restricted by the code to two-way systems with a minimum of three continuous spans, successive span lengths that do not differ by more than one-third, columns with offset not more than 10% of the span, and all loads are due to gravity only and uniformly distributed with live load not exceeding three times dead load. The direct design method involves three fundamental steps: (1) determine the total factored static moment; (2) distribute the static moment to negative and positive sections;

and (3) distribute moments to column and middle strips and to beams, if any. The total factored static moment M_o for a span bounded laterally by the centerlines of adjacent panels (see Figure 4.6) is given by

$$M_o = \frac{w_u l_2 l_n^2}{8} \quad (4.112)$$

In an interior span, $0.65 M_o$ is assigned to each negative section and $0.35 M_o$ is assigned to the positive section. In an end span, M_o is distributed according to Table 4.9. If the ratio of dead load to live load is less than 2, the effect of pattern loading is accounted for by increasing the positive moment following provisions in ACI Section 13.6.10. Negative and positive moments are then proportioned to the column strip following the percentages in Table 4.10, where β_t is the ratio of the torsional stiffness of edge beam section to flexural stiffness of a width of slab equal to span length of beam. The remaining moment not resisted by the column strip is proportionately assigned to the corresponding half middle strip. If beams are present, they are proportioned to resist 85% of column strip moments. When $(\alpha l_2 / l_1)$ is less than 1.0, the proportion of column strip moments resisted by beams is obtained by linear interpolation between 85% and zero. The shear in beams is determined from loads acting on tributary areas projected from the panel corners at 45 degrees.

TABLE 4.9 Direct Design Method—Distribution of Moment in End Span

	(1)	(2)	(3)		(5)
		Slab with	Slab without beams between interior supports		
	Exterior edge unrestrained	beams between all supports	Without edge beam	With edge beam	Exterior edge fully restrained
Interior negative-factored moment	0.75	0.70	0.70	0.70	0.65
Positive-factored moment	0.63	0.57	0.52	0.50	0.35
Exterior negative-factored moment	0	0.16	0.26	0.30	0.65

From ACI Committee 318. 1992. *Building Code Requirements for Reinforced Concrete and Commentary, ACI 318-89 (Revised 92) and ACI 318R-89 (Revised 92)*, Detroit, MI. With permission.

TABLE 4.10 Proportion of Moment to Column Strip in Percent

Interior negative-factored moment				
ℓ_2 / ℓ_1		0.5	1.0	2.0
$(\alpha_1 \ell_2 / \ell_1) = 0$		75	75	75
$(\alpha_1 \ell_2 / \ell_1) \geq 1.0$		90	75	45
Positive-factored moment				
$(\alpha_1 \ell_2 / \ell_1) = 0$	$B_t = 0$	100	100	100
	$B_t \geq 2.5$	75	75	75
$(\alpha_1 \ell_2 / \ell_1) \geq 1.0$	$B_t = 0$	100	100	100
	$B_t = 2.5$	90	75	45
Exterior negative-factored moment				
$(\alpha_1 \ell_2 / \ell_1) = 0$		60	60	60
$(\alpha_1 \ell_2 / \ell_1) \geq 1.0$		90	75	45

From ACI Committee 318. 1992. *Building Code Requirements for Reinforced Concrete and Commentary, ACI 318-89 (Revised 92) and ACI 318R-89 (Revised 92)*, Detroit, MI. With permission.

4.7.5 Equivalent Frame Method

For two-way systems not meeting the geometric or loading preconditions of the direct design method, design moments may be computed by the equivalent frame method. This is a more general method and involves the representation of the three-dimensional slab system by dividing it into a series of two-dimensional “equivalent” frames (Figure 4.6). The complete analysis of a two-way system consists of analyzing the series of equivalent interior and exterior frames that span longitudinally and transversely through the system. Each equivalent frame, which is centered on a column line and bounded by the center lines of the adjacent panels, comprises a horizontal slab-beam strip and equivalent columns extending above and below the slab beam (Figure 4.7). This structure is analyzed

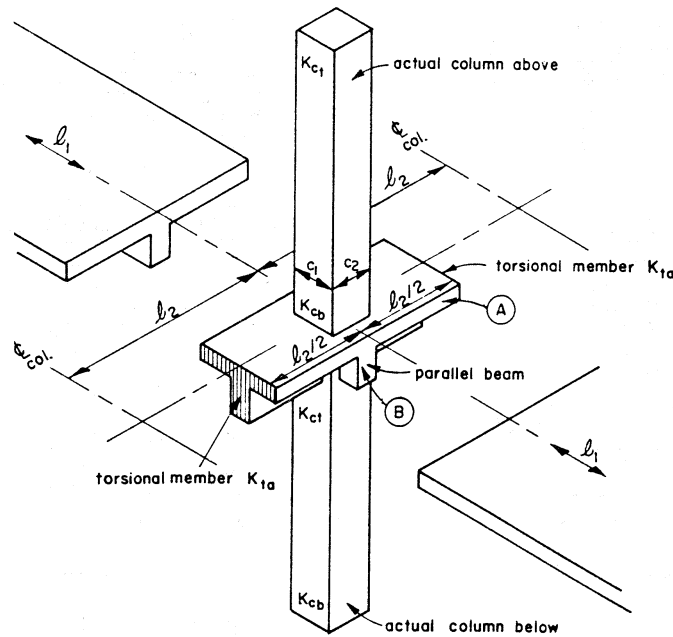

FIGURE 4.7: Equivalent column (columns plus torsional members).

as a frame for loads acting in the plane of the frame, and the moments obtained at critical sections across the slab-beam strip are distributed to the column strip, middle strip, and beam in the same manner as the direct design method (see Table 4.10). In its original development, the equivalent frame method assumed that analysis would be done by moment distribution. Presently, frame analysis is more easily accomplished in design practice with computers using general purpose programs based on the direct stiffness method. Consequently, the equivalent frame method is now often used as a method for modeling a two-way system for computer analysis.

For the different types of two-way systems, the moment of inertias for modeling the slab-beam element of the equivalent frame are indicated in Figure 4.8. Moments of inertia of slab beams are based on the gross area of concrete; the variation in moment of inertia along the axis is taken into account, which in practice would mean that a node would be located on the computer model where a change of moment of inertia occurs. To account for the increased stiffness between the center of the column and the face of column, beam, or capital, the moment of inertia is divided by the quantity $(1 - c_2/l_2)^2$, where c_2 and l_2 are measured transverse to the direction of the span. For

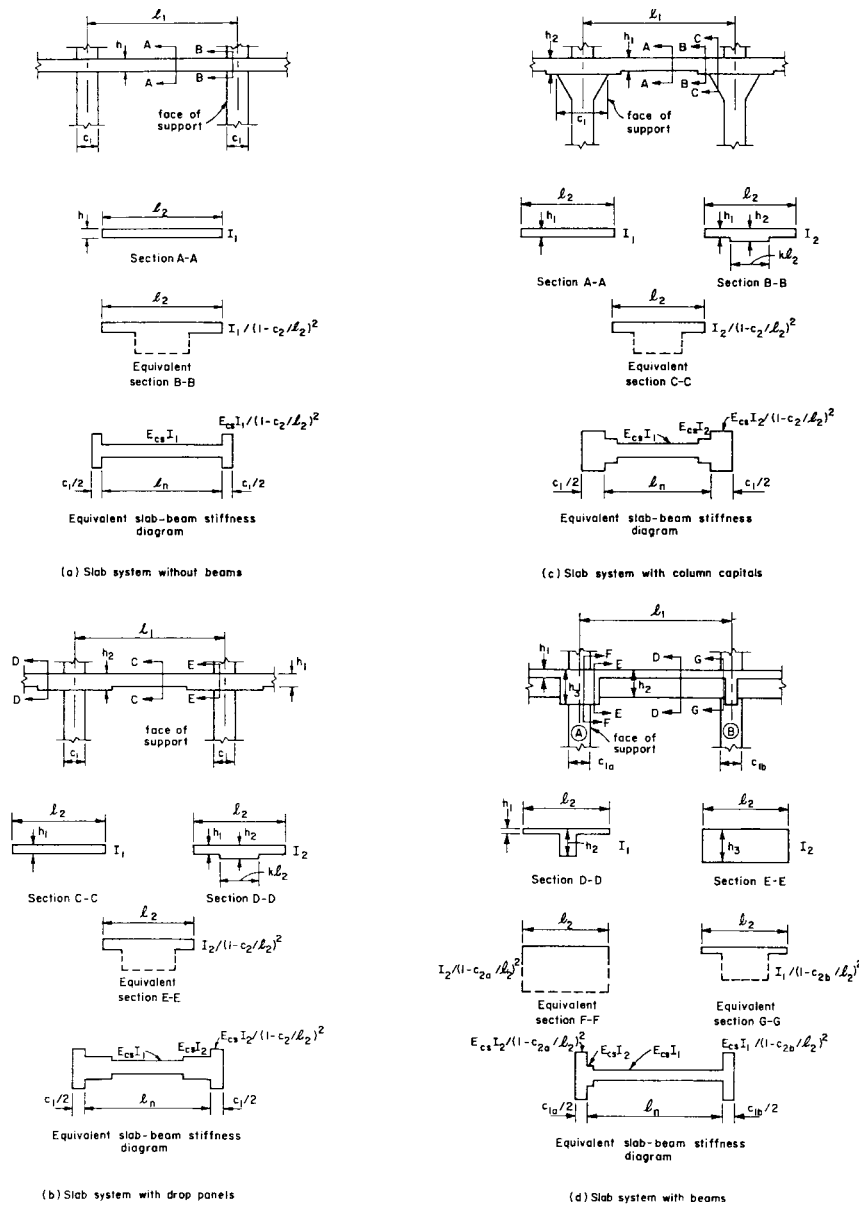

FIGURE 4.8: Slab-beam stiffness by equivalent frame method. (From ACI Committee 318. 1992. *Building Code Requirements for Reinforced Concrete and Commentary, ACI 318-89 (Revised 92) and ACI 318R-89 (Revised 92)*, Detroit, MI. With permission.)

column modeling, the moment of inertia at any cross-section outside of joints or column capitals may be based on the gross area of concrete, and the moment of inertia from the top to bottom of the slab-beam joint is assumed infinite.

Torsion members (Figure 4.7) are elements in the equivalent frame that provide moment transfer between the horizontal slab beam and vertical columns. The cross-section of torsional members are assumed to consist of the portion of slab and beam having a width according to the conditions depicted

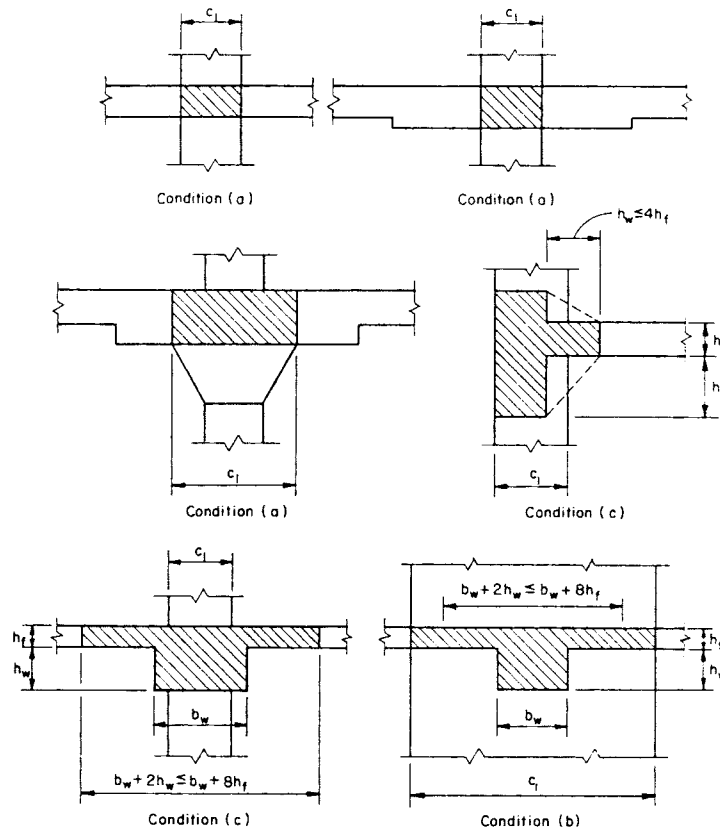

FIGURE 4.9: Torsional members. (From ACI Committee 318. 1992. *Building Code Requirements for Reinforced Concrete and Commentary, ACI 318-89 (Revised 92) and ACI 318R-89 (Revised 92)*, Detroit, MI. With permission.)

in Figure 4.9. The stiffness K_t of the torsional member is calculated by the following expression:

$$K_t = \sum \frac{9E_{cs}C}{l_2 \left(1 - \frac{c_2}{l_2}\right)^3} \quad (4.113)$$

where E_{cs} is the modulus of elasticity of the slab concrete and torsional constant C may be evaluated by dividing the cross-section into separate rectangular parts and carrying out the following summation:

$$C = \sum \left(1 - 0.63\frac{x}{y}\right) \frac{x^3y}{3} \quad (4.114)$$

where x and y are the shorter and longer dimension, respectively, of each rectangular part. Where beams frame into columns in the direction of the span, the increased torsional stiffness K_{ta} is obtained by multiplying the value K_t obtained from Equation 4.113 by the ratio of (a) moment inertia of slab with such beam, to (b) moment of inertia of slab without such beam. Various ways have been suggested for incorporating torsional members into a computer model of an equivalent frame. The model implied by the ACI Code is one that has the slab beam connected to the torsional members, which are projected out of the plane of the columns. Others have suggested that the torsional

members be replaced by rotational springs at column ends or, alternatively, at the slab-beam ends. Or, instead of rotational springs, columns may be modeled with an equivalent value of the moment of inertia modified by the equivalent column stiffness K_{ec} given in the commentary of the code. Using Figure 4.7, K_{ec} is computed as

$$K_{ec} = \frac{K_{ct} + K_{cb}}{1 + \frac{K_{ct} + K_{cb}}{K_{ta} + K_{tb}}} \quad (4.115)$$

where K_{ct} and K_{cb} are the top and bottom flexural stiffnesses of the column.

4.7.6 Detailing

The ACI Code specifies that reinforcement in two-way slabs without beams have minimum extensions as prescribed in Figure 4.10. Where adjacent spans are unequal, extensions of negative moment

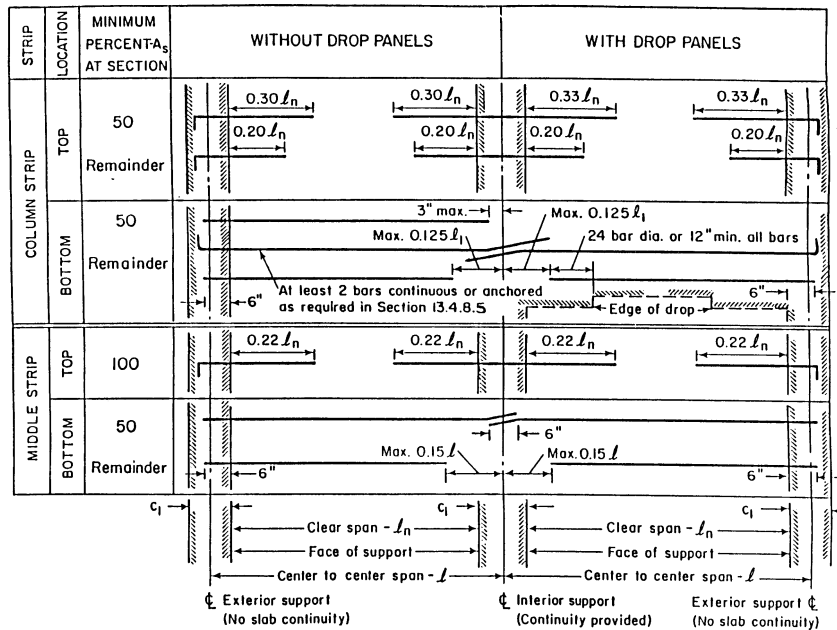

FIGURE 4.10: Minimum extensions for reinforcement in two-way slabs without beams. (From ACI Committee 318. 1992. *Building Code Requirements for Reinforced Concrete and Commentary, ACI 318-89 (Revised 92) and ACI 318R-89 (Revised 92)*, Detroit, MI. With permission.)

reinforcement shall be based on the longer span. Bent bars may be used only when the depth-span ratio permits use of bends 45 degrees or less. And at least two of the column strip bottom bars in each direction shall be continuous or spliced at the support with Class A splices or anchored within support. These bars must pass through the column and be placed within the column core. The purpose of this "integrity steel" is to give the slab some residual capacity following a single punching shear failure.

The ACI Code requires drop panels to extend in each direction from centerline of support a distance not less than one-sixth the span length, and the drop panel must project below the slab at

least one-quarter of the slab thickness. The effective support area of a column capital is defined by the intersection of the bottom surface of the slab with the largest right circular cone whose surfaces are located within the column and capital and are oriented no greater than 45 degrees to the axis of the column.

4.8 Frames

A structural frame is a three-dimensional structural system consisting of straight members that are built monolithically and have rigid joints. The frame may be one bay long and one story high—such as portal frames and gable frames—or it may consist of multiple bays and stories. All members of frame are considered continuous in the three directions, and the columns participate with the beams in resisting external loads.

Consideration of the behavior of reinforced concrete frames at and near the ultimate load is necessary to determine the possible distributions of bending moment, shear force, and axial force that could be used in design. It is possible to use a distribution of moments and forces different from that given by linear elastic structural analysis if the critical sections have sufficient ductility to allow redistribution of actions to occur as the ultimate load is approached. Also, in countries that experience earthquakes, a further important design is the ductility of the structure when subjected to seismic-type loading, since present seismic design philosophy relies on energy dissipation by inelastic deformations in the event of major earthquakes.

4.8.1 Analysis of Frames

A number of methods have been developed over the years for the analysis of [continuous beams](#) and frames. The so-called classical methods—such as application of the theorem of three moments, the method of least work, and the general method of consistent deformation—have proved useful mainly in the analysis of continuous beams having few spans or of very simple frames. For the more complicated cases usually met in practice, such methods prove to be exceedingly tedious, and alternative approaches are preferred. For many years the closely related methods of slope deflection and moment distribution provided the basic analytical tools for the analysis of indeterminate concrete beams and frames. In offices with access to high-speed digital computers, these have been supplanted largely by matrix methods of analysis. Where computer facilities are not available, moment distribution is still the most common method. Approximate methods of analysis, based either on an assumed shape of the deformed structure or on moment coefficients, provide a means for rapid estimation of internal forces and moments. Such estimates are useful in preliminary design and in checking more exact solutions, and in structures of minor importance may serve as the basis for final design.

Slope Deflection

The method of slope deflection entails writing two equations for each member of a continuous frame, one at each end, expressing the end moment as the sum of four contributions: (1) the restraining moment associated with an assumed fixed-end condition for the loaded span, (2) the moment associated with rotation of the tangent to the elastic curve at the near end of the member, (3) the moment associated with rotation of the tangent at the far end of the member, and (4) the moment associated with translation of one end of the member with respect to the other. These equations are related through application of requirements of equilibrium and compatibility at the joints. A set of simultaneous, linear algebraic equations results for the entire structure, in which the structural displacements are unknowns. Solution for these displacements permits the calculation of all internal forces and moments.

This method is well suited to solving continuous beams, provided there are not very many spans.

Its usefulness is extended through modifications that take advantage of symmetry and antisymmetry, and of hinge-end support conditions where they exist. However, for multistory and multibay frames in which there are a large number of members and joints, and which will, in general, involve translation as well as rotation of these joints, the effort required to solve the correspondingly large number of simultaneous equations is prohibitive. Other methods of analysis are more attractive.

Moment Distribution

The method of moment distribution was developed to solve problems in frame analysis that involve many unknown joint displacements. This method can be regarded as an iterative solution of the slope-deflection equations. Starting with fixed-end moments for each member, these are modified in a series of cycles, each converging on the precise final result, to account for rotation and translation of the joints. The resulting series can be terminated whenever one reaches the degree of accuracy required. After obtaining member-end moments, all member stress resultants can be obtained by use of the laws of statics.

Matrix Analysis

Use of matrix theory makes it possible to reduce the detailed numerical operations required in the analysis of an indeterminate structure to systematic processes of matrix manipulation which can be performed automatically and rapidly by computer. Such methods permit the rapid solution of problems involving large numbers of unknowns. As a consequence, less reliance is placed on special techniques limited to certain types of problems; powerful methods of general applicability have emerged, such as the matrix displacement method. Account can be taken of such factors as rotational restraint provided by members perpendicular to the plane of a frame. A large number of alternative loadings may be considered. Provided that computer facilities are available, highly precise analyses are possible at lower cost than for approximate analyses previously employed.

Approximate Analysis

In spite of the development of refined methods for the analysis of beams and frames, increasing attention is being paid to various approximate methods of analysis. There are several reasons for this. Prior to performing a complete analysis of an indeterminate structure, it is necessary to estimate the proportions of its members in order to know their relative stiffness upon which the analysis depends. These dimensions can be obtained using approximate analysis. Also, even with the availability of computers, most engineers find it desirable to make a rough check of results—using approximate means—to detect gross errors. Further, for structures of minor importance, it is often satisfactory to design on the basis of results obtained by rough calculation.

Provided that points of inflection (locations in members at which the bending moment is zero and there is a reversal of curvature of the elastic curve) can be located accurately, the stress resultants for a framed structure can usually be found on the basis of static equilibrium alone. Each portion of the structure must be in equilibrium under the application of its external loads and the internal stress resultants. The use of approximate analysis in determining stress resultants in frames is illustrated using a simple rigid frame in Figure 4.11.

ACI Moment Coefficients

The ACI Code [1] includes moment and shear coefficients that can be used for the analysis of buildings of usual types of construction, span, and story heights. They are given in ACI Code Sec. 8.3.3. The ACI coefficients were derived with due consideration of several factors: a maximum allowable ratio of live to dead load (3:1); a maximum allowable span difference (the larger of two adjacent spans not exceed the shorter by more than 20%); the fact that reinforced concrete beams are never simply supported but either rest on supports of considerable width, such as walls, or are

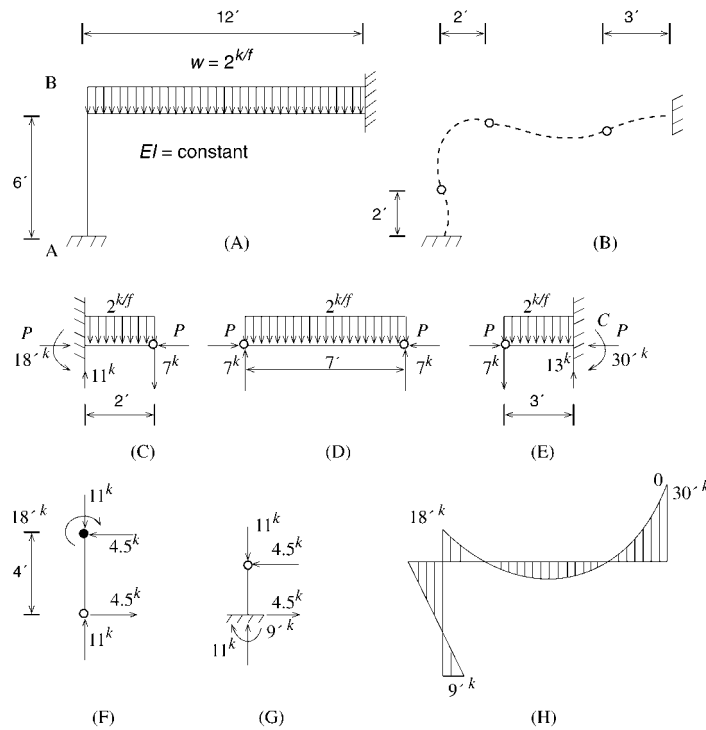

FIGURE 4.11: Approximate analysis of rigid frame.

built monolithically like columns; and other factors. Since all these influences are considered, the ACI coefficients are necessarily quite conservative, so that actual moments in any particular design are likely to be considerably smaller than indicated. Consequently, in many reinforced concrete structures, significant economy can be effected by making a more precise analysis.

Limit Analysis

Limit analysis in reinforced concrete refers to the redistribution of moments that occurs throughout a structure as the steel reinforcement at a critical section reaches its yield strength. Under working loads, the distribution of moments in a statically indeterminate structure is based on elastic theory, and the whole structure remains in the elastic range. In limit design, where factored loads are used, the distribution of moments at failure when a mechanism is reached is different from that distribution based on elastic theory. The ultimate strength of the structure can be increased as more sections reach their ultimate capacity. Although the yielding of the reinforcement introduces large deflections, which should be avoided under service, a statically indeterminate structure does not collapse when the reinforcement of the first section yields. Furthermore, a large reserve of strength is present between the initial yielding and the collapse of the structure.

In steel design the term *plastic design* is used to indicate the change in the distribution of moments in the structure as the steel fibers, at a critical section, are stressed to their yield strength. Limit analysis of reinforced concrete developed as a result of earlier research on steel structures. Several studies had been performed on the principles of limit design and the rotation capacity of reinforced concrete [plastic hinges](#).

Full utilization of the plastic capacity of reinforced concrete beams and frames requires an extensive analysis of all possible mechanisms and an investigation of rotation requirements and capacities at

all proposed hinge locations. The increase of design time may not be justified by the limited gains obtained. On the other hand, a restricted amount of redistribution of elastic moments can safely be made without complete analysis and may be sufficient to obtain most of the advantages of limit analysis.

A limited amount of redistribution is permitted under the ACI Code, depending upon a rough measure of available ductility; without explicit calculation of rotation requirements and capacities. The ratio ρ/ρ_b —or in the case of doubly reinforced members, $(\rho - \rho')/\rho_b$ —is used as an indicator of rotation capacity, where ρ_b is the balanced steel ratio. For singly reinforced members with $\rho = \rho_b$, experiments indicate almost no rotation capacity, since the concrete strain is nearly equal to ε_{cu} when steel yielding is initiated. Similarly, in a doubly reinforced member, when $\rho - \rho' = \rho_b$, very little rotation will occur after yielding before the concrete crushes. However, when ρ or $\rho - \rho'$ is low, extensive rotation is usually possible. Accordingly, ACI Code Sec. 8.3 provides as follows:

Except where approximate values for moments are used, it is permitted to increase or decrease negative moments calculated by elastic theory at supports of continuous flexural members for any assumed loading arrangement by not more than 20 $[1 - (\rho - \rho')/\rho_b]$ percent. The modified negative moments shall be used for calculating moments at sections within the spans. Redistribution of negative moments shall be made only when the section at which moment is reduced is so designed that ρ or $\rho - \rho'$ is not greater than $0.5 \rho_b$ [1992].

4.8.2 Design for Seismic Loading

The ACI Code contains provisions that are currently considered to be the minimum requirements for producing a monolithic concrete structure with adequate proportions and details to enable the structure to sustain a series of oscillations into the inelastic range of response without critical decay in strength. The provisions are intended to apply to reinforced concrete structures located in a seismic zone where major damage to construction has a high possibility of occurrence, and are designed with a substantial reduction in total lateral seismic forces due to the use of lateral load-resisting systems consisting of ductile moment-resisting frames. The provisions for frames are divided into sections on flexural members, columns, and joints of frames. Some of the important points stated are summarized below.

Flexural Members

Members having a factored axial force not exceeding $A_g f'_c/10$, where A_g is gross section of area (in.²), are regarded as flexural members. An upper limit is placed on the flexural steel ratio ρ . The maximum value of ρ should not exceed 0.025. Provision is also made to ensure that a minimum quantity of top and bottom reinforcement is always present. Both the top and the bottom steel are to have a steel ratio of at least $200/f_y$, with the steel yield strength f_y in psi throughout the length of the member. Recommendations are also made to ensure that sufficient steel is present to allow for unforeseen shifts in the points of contraflexure. At column connections, the positive moment capacity should be at least 50% of the negative moment capacity, and the reinforcement should be continuous through columns where possible. At external columns, beam reinforcement should be terminated in the far face of the column using a hook plus any additional extension necessary for anchorage.

The design shear force V_e should be determined from consideration of the static forces on the portion of the member between faces of the joints. It should be assumed that moments of opposite sign corresponding to probable strength M_{pr} act at the joint faces and that the member is loaded with the factored tributary gravity load along its span. Figure 4.12 illustrates the calculation. Minimum web reinforcement is provided throughout the length of the member, and spacing should not exceed

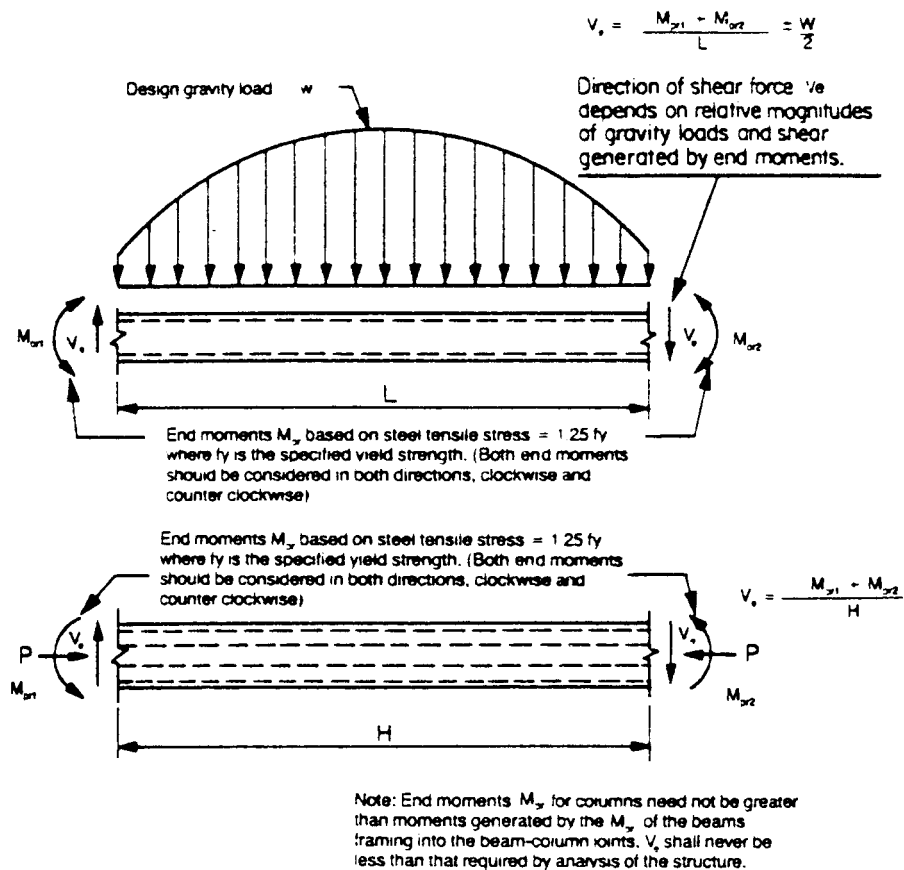

FIGURE 4.12: Design shears for girders and columns. (From ACI Committee 318. 1992. *Building Code Requirements for Reinforced Concrete and Commentary, ACI 318-89 (Revised 92) and ACI 318R-89 (Revised 92)*, Detroit, MI. With permission.)

$d/4$ in plastic hinge zones and $d/2$ elsewhere, where d is **effective depth** of member. The stirrups should be closed around bars required to act as compression reinforcement and in plastic hinge regions, and the spacing should not exceed specified values.

Columns

Members having a factored axial force exceeding $A_g f'_c / 10$ are regarded as columns of frames serving to resist earthquake forces. These members should satisfy the conditions that the shortest cross-sectional dimension—measured on a straight line passing through the geometric centroid—should not be less than 12 in. and that the ratio of the shortest cross-sectional dimension to the perpendicular dimension should not be less than 0.4. The flexural strengths of the columns should satisfy

$$\sum M_e \geq (6/5) \sum M_g \quad (4.116)$$

where $\sum M_e$ is sum of moments, at the center of the joint, corresponding to the design flexural strength of the columns framing into that joint and where $\sum M_g$ is sum of moments, at the center of the joint, corresponding to the design flexural strengths of the girders framing into that joint. Flexural strengths should be summed such that the column moments oppose the beam moments.

Equation 4.116 should be satisfied for beam moments acting in both directions in the vertical plane of the frame considered. The requirement is intended to ensure that plastic hinges form in the girders rather than the columns.

The longitudinal reinforcement ratio is limited to the range of 0.01 to 0.06. The lower bound to the reinforcement ratio refers to the traditional concern for the effects of time-dependent deformations of the concrete and the desire to have a sizable difference between the cracking and yielding moments. The upper bound reflects concern for steel congestion, load transfer from floor elements to column in low-rise construction, and the development of large shear stresses. Lap splices are permitted only within the center half of the member length and should be proportioned as tension splices. Welded splices and mechanical connections are allowed for splicing the reinforcement at any section, provided not more than alternate longitudinal bars are spliced at a section and the distance between splices is 24 in. or more along the longitudinal axis of the reinforcement.

If Equation 4.116 is not satisfied at a joint, columns supporting reactions from that joint should be provided with transverse reinforcement over their full height to confine the concrete and provide lateral support to the reinforcement. Where a spiral is used, the ratio of volume of spiral reinforcement to the core volume confined by the spiral reinforcement, ρ_s , should be at least that given by

$$\rho_s = 0.45 \frac{f'_c}{f_y} \left(\frac{A_g}{A_c} - 1 \right) \quad (4.117)$$

but not less than $0.12 f'_c/f_{yh}$, where A_c is the area of core of spirally reinforced compression member measured to outside diameter of spiral in in.² and f_{yh} is the specified yield strength of transverse reinforcement in psi. When rectangular reinforcement hoop is used, the total cross-sectional area of rectangular hoop reinforcement should not be less than that given by

$$A_{sh} = 0.3 (sh_c f'_c/f_{yh}) [(A_g/A_{ch}) - 1] \quad (4.118)$$

$$A_{sh} = 0.09sh_c f'_c/f_{yh} \quad (4.119)$$

where s is the spacing of transverse reinforcement measured along the longitudinal axis of column, h_c is the cross-sectional dimension of column core measured center-to-center of confining reinforcement, and A_{sh} is the total cross-sectional area of transverse reinforcement (including crossties) within spacing s and perpendicular to dimension h_c . Supplementary crossties, if used, should be of the same diameter as the hoop bar and should engage the hoop with a hook. Special transverse confining steel is required for the full height of columns that support discontinuous [shear walls](#).

The design shear force V_e should be determined from consideration of the maximum forces that can be generated at the faces of the joints at each end of the column. These joint forces should be determined using the maximum probable moment strength M_{pr} of the column associated with the range of factored axial loads on the column. The column shears need not exceed those determined from joint strengths based on the probable moment strength M_{pr} , of the transverse members framing into the joint. In no case should V_e be less than the factored shear determined by analysis of the structure [Figure 4.12](#).

Joins of Frames

Development of inelastic rotations at the faces of joints of reinforced concrete frames is associated with strains in the flexural reinforcement well in excess of the yield strain. Consequently, joint shear force generated by the flexural reinforcement is calculated for a stress of $1.25 f_y$ in the reinforcement.

Within the depth of the shallowed framing member, transverse reinforcement equal to at least one-half the amount required for the column reinforcement should be provided where members frame into all four sides of the joint and where each member width is at least three-fourths the column width. Transverse reinforcement as required for the column reinforcement should be provided through the

joint to provide confinement for longitudinal beam reinforcement outside the column core if such confinement is not provided by a beam framing into the joint.

The nominal shear strength of the joint should not be taken greater than the forces specified below for normal weight aggregate concrete:

$$20\sqrt{f'_c A_j} \quad \text{for joints confined on all four faces}$$

$$15\sqrt{f'_c A_j} \quad \text{for joints confined on three faces or on two opposite faces}$$

$$12\sqrt{f'_c A_j} \quad \text{for others}$$

where A_j is the effective cross-sectional area within a joint in a plane parallel to plane of reinforcement generating shear in the joint (Figure 4.13). A member that frames into a face is considered to provide

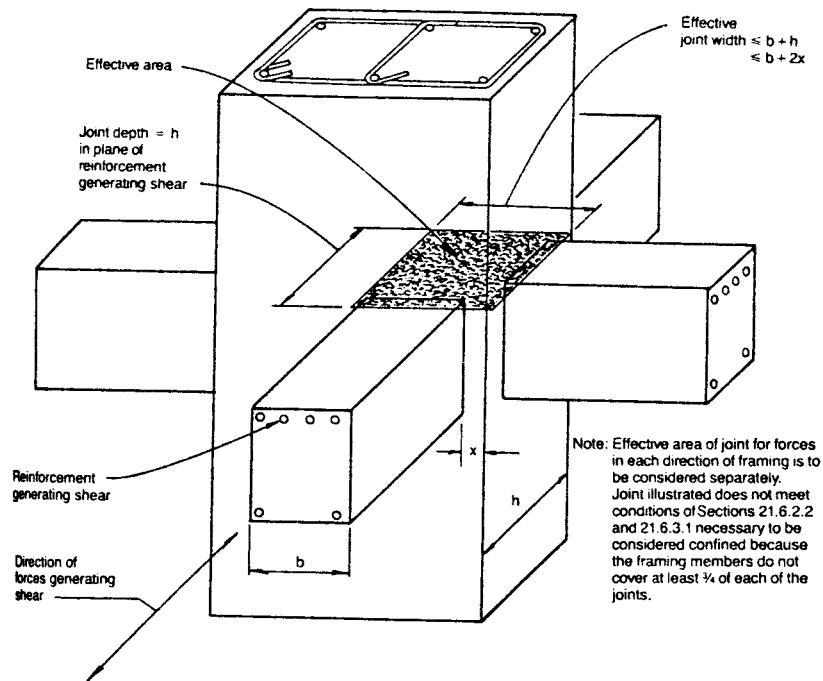

FIGURE 4.13: Effective area of joint. (From ACI Committee 318. 1992. *Building Code Requirements for Reinforced Concrete and Commentary, ACI 318-89 (Revised 92) and ACI 318R-89 (Revised 92)*, Detroit, MI. With permission.)

confinement to the joint if at least three-quarters of the face of the joint is covered by the framing member. A joint is considered to be confined if such confining members frame into all faces of the joint. For lightweight-aggregate concrete, the nominal shear strength of the joint should not exceed three-quarters of the limits given above.

Details of minimum development length for deformed bars with standard hooks embedded in normal and lightweight concrete and for straight bars are contained in ACI Code Sec. 21.6.4.

4.9 Brackets and Corbels

Brackets and corbels are cantilevers having shear span depth ratio, a/d , not greater than unity. The shear span a is the distance from the point of load to the face of support, and the distance d shall be measured at face of support (see Figure 4.14).

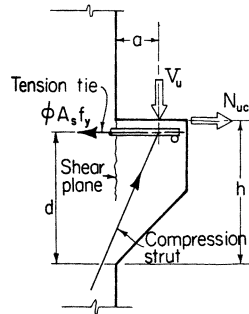

FIGURE 4.14: Structural action of a corbel. (From ACI Committee 318. 1992. *Building Code Requirements for Reinforced Concrete and Commentary, ACI 318-89 (Revised 92) and ACI 318R-89 (Revised 92)*, Detroit, MI. With permission.)

The corbel shown in Figure 4.14 may fail by shearing along the interface between the column and the corbel by yielding of the tension tie, by crushing or splitting of the compression strut, or by localized bearing or shearing failure under the loading plate.

The depth of a bracket or corbel at its outer edge should be less than one-half of the required depth d at the support. Reinforcement should consist of main tension bars with area A_s and shear reinforcement with area A_h (see Figure 4.15 for notation). The area of primary tension reinforcement

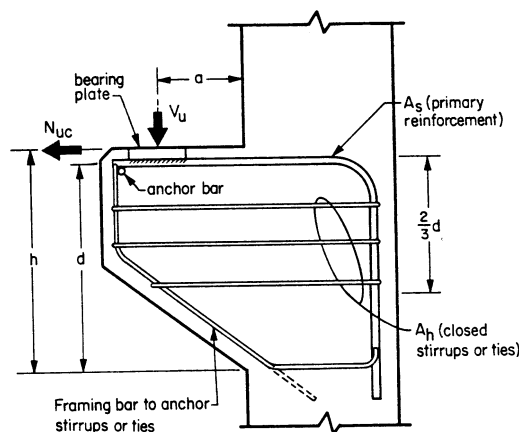

FIGURE 4.15: Notation used. (From ACI Committee 318. 1992. *Building Code Requirements for Reinforced Concrete and Commentary, ACI 318-89 (Revised 92) and ACI 318R-89 (Revised 92)*, Detroit, MI. With permission.)

A_s should be made equal to the greater of $(A_f + A_n)$ or $(2A_{vf}/3 - A_n)$, where A_f is the flexural reinforcement required to resist moment $[V_u a + N_{uc}(h - d)]$, A_n is the reinforcement required to resist tensile force N_{uc} , and A_{vf} is the shear-friction reinforcement required to resist shear V_u :

$$A_f = \frac{M_u}{\phi f_y j d} = \frac{V_u a + N_{uc}(h - d)}{\phi f_y j d} \quad (4.120)$$

$$A_n = \frac{N_{uc}}{\phi f_y} \quad (4.121)$$

$$A_{vf} = \frac{V_u}{\phi f_y \mu} \quad (4.122)$$

In the above equations, f_y is the reinforcement yield strength; ϕ is 0.9 for Equation 4.120 and 0.85 for Equations 4.121 and 4.122. In Equation 4.120, the lever arm $j d$ can be approximated for all practical purposes in most cases as $0.85 d$. Tensile force N_{uc} in Equation 4.121 should not be taken less than $0.2 V_u$ unless special provisions are made to avoid tensile forces. Tensile force N_{uc} should be regarded as a live load even when tension results from creep, shrinkage, or temperature change. In Equation 4.122, $V_u/\phi (= V_n)$ should not be taken greater than $0.2 f'_c b_w d$ nor $800 b_w d$ in pounds in normal-weight concrete. For “all-lightweight” or “sand-lightweight” concrete, shear strength V_n should not be taken greater than $(0.2 - 0.07 a/d) f'_c b_w d$ nor $(800 - 280 a/d) b_w d$ in pounds. The coefficient of friction μ in Equation 4.122 should be 1.4λ for concrete placed monolithically, 1.0λ for concrete placed against hardened concrete with surface intentionally roughened, 0.6λ for concrete placed against hardened concrete not intentionally roughened, and 0.7λ for concrete anchored to as-rolled structural steel by headed studs or by reinforcing bars, where λ is 1.0 for normal weight concrete, 0.85 for “sand-lightweight” concrete, and 0.75 for “all-lightweight” concrete. Linear interpolation of λ is permitted when partial sand replacement is used.

The total area of closed stirrups or ties A_h parallel to A_s should not be less than $0.5(A_s - A_n)$ and should be uniformly distributed within two-thirds of the depth of the bracket adjacent to A_s .

At front face of bracket or corbel, primary tension reinforcement A_s should be anchored in one of the following ways: (a) by a structural weld to a transverse bar of at least equal size; weld to be designed to develop specified yield strength f_y of A_s bars; (b) by bending primary tension bars A_s back to form a horizontal loop, or (c) by some other means of positive anchorage. Also, to ensure development of the yield strength of the reinforcement A_s near the load, bearing area of load on bracket or corbel should not project beyond straight portion of primary tension bars A_s , nor project beyond interior face of transverse anchor bar (if one is provided). When corbels are designed to resist horizontal forces, the bearing plate should be welded to the tension reinforcement A_s .

4.10 Footings

Footings are structural members used to support columns and walls and to transmit and distribute their loads to the soil in such a way that (a) the load bearing capacity of the soil is not exceeded, (b) excessive settlement, differential settlement, and rotations are prevented, and (c) adequate safety against overturning or sliding is maintained. When a column load is transmitted to the soil by the footing, the soil becomes compressed. The amount of settlement depends on many factors, such as the type of soil, the load intensity, the depth below ground level, and the type of footing. If different footings of the same structure have different settlements, new stresses develop in the structure. Excessive differential settlement may lead to the damage of nonstructural members in the buildings, even failure of the affected parts.

Vertical loads are usually applied at the centroid of the footing. If the resultant of the applied loads does not coincide with the centroid of the bearing area, a bending moment develops. In this case,

the pressure on one side of the footing will be greater than the pressure on the other side, causing higher settlement on one side and a possible rotation of the footing.

If the bearing soil capacity is different under different footings—for example, if the footings of a building are partly on soil and partly on rock—a differential settlement will occur. It is customary in such cases to provide a joint between the two parts to separate them, allowing for independent settlement.

4.10.1 Types of Footings

Different types of footings may be used to support building columns or walls. The most commonly used ones are illustrated in Figure 4.16(a–g). A simple file footing is shown in Figure 4.16(h).

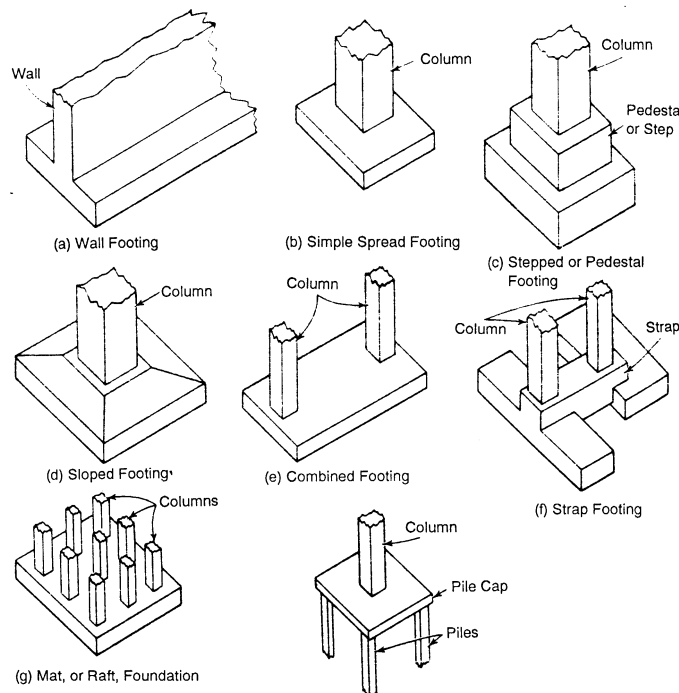

FIGURE 4.16: Common types of footings for walls and columns. (From ACI Committee 340. 1990. *Design Handbook in Accordance with the Strength Design Method of ACI 318-89*. Volume 2, SP-17. With permission.)

For walls, a spread footing is a slab wider than the wall and extending the length of the wall [Figure 4.16(a)]. Square or rectangular slabs are used under single columns [Figure 4.16(b–d)]. When two columns are so close that their footings would merge or nearly touch, a combined footing [Figure 4.16(e)] extending under the two should be constructed. When a column footing cannot project in one direction, perhaps because of the proximity of a property line, the footing may be helped out by an adjacent footing with more space; either a combined footing or a strap (cantilever) footing [Figure 4.16(f)] may be used under the two.

For structures with heavy loads relative to soil capacity, a mat or raft foundation [Figure 4.16(g)] may prove economical. A simple form is a thick, two-way-reinforced-concrete slab extending under

the entire structure. In effect, it enables the structure to float on the soil, and because of its rigidity it permits negligible differential settlement. Even greater rigidity can be obtained by building the raft foundation as an inverted beam-and-girder floor, with the girders supporting the columns. Sometimes, also, inverted flat slabs are used as mat foundations.

4.10.2 Design Considerations

Footings must be designed to carry the column loads and transmit them to the soil safely while satisfying code limitations. The design procedure must take the following strength requirements into consideration:

- The area of the footing based on the allowable bearing soil capacity
- Two-way shear or punching shear
- One-way shear
- Bending moment and steel reinforcement required
- Dowel requirements
- Development length of bars
- Differential settlement

These strength requirements will be explained in the following sections.

Size of Footings

The required area of concentrically loaded footings is determined from

$$A_{\text{req}} = \frac{D + L}{q_a} \quad (4.123)$$

where q_a is allowable bearing pressure and D and L are, respectively, unfactored dead and live loads. Allowable bearing pressures are established from principles of soil mechanics on the basis of load tests and other experimental determinations. Allowable bearing pressures q_a under service loads are usually based on a [safety factor](#) of 2.5 to 3.0 against exceeding the ultimate bearing capacity of the particular soil and to keep settlements within tolerable limits. The required area of footings under the effects of wind W or earthquake E is determined from the following:

$$A_{\text{req}} = \frac{D + L + W}{1.33q_a} \quad \text{or} \quad \frac{D + L + E}{1.33q_a} \quad (4.124)$$

It should be noted that footing sizes are determined for unfactored [service loads](#) and soil pressures, in contrast to the strength design of reinforced concrete members, which utilizes factored loads and factored [nominal strengths](#).

A footing is eccentrically loaded if the supported column is not concentric with the footing area or if the column transmits—at its juncture with the footing—not only a vertical load but also a bending moment. In either case, the load effects at the footing base can be represented by the vertical load P and a bending moment M . The resulting bearing pressures are again assumed to be linearly distributed. As long as the resulting eccentricity $e = M/P$ does not exceed the kern distance k of the footing area, the usual flexure formula

$$q_{\text{max, min}} = \frac{P}{A} + \frac{M_c}{I} \quad (4.125)$$

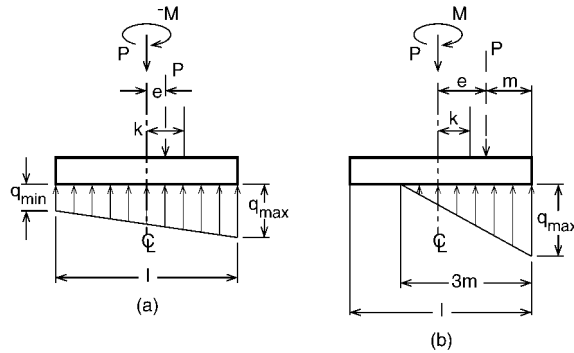

FIGURE 4.17: Assumed bearing pressures under eccentric footings.

permits the determination of the bearing pressures at the two extreme edges, as shown in Figure 4.17(a). The footing area is found by trial and error from the condition $q_{\max} \leq q_a$. If the eccentricity falls outside the kern, Equation 4.125 gives a negative value for q along one edge of the footing. Because no tension can be transmitted at the contact area between soil and footing, Equation 4.125 is no longer valid and bearing pressures are distributed as in Figure 4.17(b).

Once the required footing area has been determined, the footing must then be designed to develop the necessary strength to resist all moments, shears, and other internal actions caused by the applied loads. For this purpose, the **load factors** of the ACI Code apply to footings as to all other structural components.

Depth of footing above bottom reinforcement should not be less than 6 in. for footings on soil, nor less than 12 in. for footings on piles.

Two-Way Shear (Punching Shear)

ACI Code Sec. 11.12.2 allows a shear strength V_c of footings without shear reinforcement for two-way shear action as follows:

$$V_c = \left(2 + \frac{4}{\beta_c}\right) \sqrt{f'_c} b_o d \leq 4\sqrt{f'_c} b_o d \quad (4.126)$$

where β_c is the ratio of long side to short side of rectangular area, b_o is the perimeter of the critical section taken at $d/2$ from the loaded area (column section), and d is the effective depth of footing. This shear is a measure of the diagonal tension caused by the effect of the column load on the footing. Inclined cracks may occur in the footing at a distance $d/2$ from the face of the column on all sides. The footing will fail as the column tries to punch out part of the footing, as shown in Figure 4.18.

One-Way Shear

For footings with bending action in one direction, the critical section is located at a distance d from the face of the column. The diagonal tension at section $m-m$ in Figure 4.19 can be checked as is done in beams. The allowable shear in this case is equal to

$$\phi V_c = 2\phi\sqrt{f'_c} b d \quad (4.127)$$

where b is the width of section $m-m$. The ultimate shearing force at section $m-m$ can be calculated as follows:

$$V_u = q_u b \left(\frac{L}{2} - \frac{c}{2} - d\right) \quad (4.128)$$

where b is the side of footing parallel to section $m-m$.

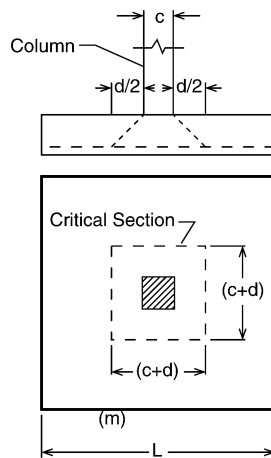

FIGURE 4.18: Punching shear (two-way).

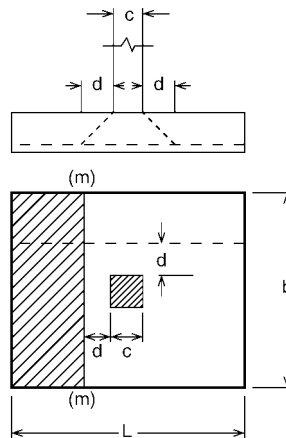

FIGURE 4.19: One-way shear.

Flexural Reinforcement and Footing Reinforcement

The theoretical sections for moment occur at face of the column (section $n-n$, Figure 4.20). The bending moment in each direction of the footing must be checked and the appropriate reinforcement must be provided. In square footings the bending moments in both directions are equal. To determine the reinforcement required, the depth of the footing in each direction may be used. As the bars in one direction rest on top of the bars in the other direction, the effective depth d varies with the diameter of the bars used. The value of d_{\min} may be adopted.

The depth of footing is often controlled by the shear, which requires a depth greater than that required by the bending moment. The steel reinforcement in each direction can be calculated in the case of flexural members as follows:

$$A_s = \frac{M_u}{\phi f_y (d - a/2)} \quad (4.129)$$

The minimum steel percentage requirement in flexural member is equal to $200/f_y$. However, ACI Code Sec. 10.5.3 indicates that for structural slabs of uniform thickness, the minimum area

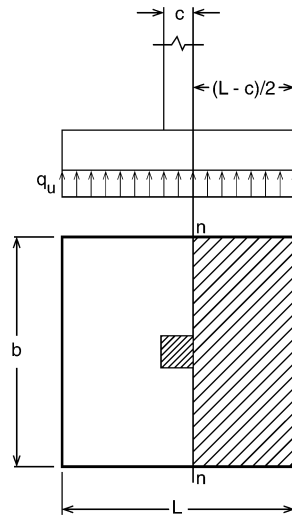

FIGURE 4.20: Critical section of bending moment.

and maximum spacing of steel in the direction of bending should be as required for shrinkage and temperature reinforcement. This last minimum steel reinforcement is very small and a higher minimum reinforcement ratio is recommended, but not greater than $200/f_y$.

The reinforcement in one-way footings and two-way footings must be distributed across the entire width of the footing. In the case of two-way rectangular footings, ACI Code Sec 15.4.4 specifies that in the long direction the total reinforcement must be placed uniformly within a band width equal to the length of the short side of the footing according to

$$\frac{\text{Reinforcement band width}}{\text{Total reinforcement in short direction}} = \frac{2}{\beta + 1} \quad (4.130)$$

where β is the ratio of the long side to the short side of the footing. The band width must be centered on the centerline of the column (Figure 4.21). The remaining reinforcement in the short direction must be uniformly distributed outside the band width. This remaining reinforcement percentage should not be less than required for shrinkage and temperature.

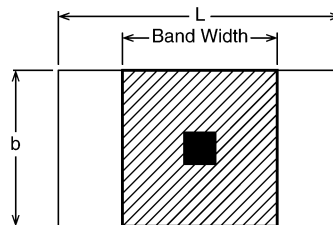

FIGURE 4.21: Band width for reinforcement distribution.

When structural steel columns or masonry walls are used, the critical sections for moments in footing are taken at halfway between the middle and the edge of masonry walls, and halfway between the face of the column and the edge of the steel base plate (ACI Code Sec. 15.4.2).

Bending Capacity of Column at Base

The loads from the column act on the footing at the base of the column, on an area equal to the area of the column cross-section. Compressive forces are transferred to the footing directly by bearing on the concrete. Tensile forces must be resisted by reinforcement, neglecting any contribution by concrete.

Forces acting on the concrete at the base of the column must not exceed the bearing strength of concrete as specified by the ACI Code Sec.10.15:

$$N = \phi (0.85 f'_c A_1) \quad (4.131)$$

where ϕ is 0.7 and A_1 is the bearing area of the column. The value of the bearing strength given in Equation 4.131 may be multiplied by a factor $\sqrt{A_2/A_1} \leq 2.0$ for bearing on footings when the supporting surface is wider on all sides other than the loaded area. Here A_2 is the area of the part of the supporting footing that is geometrically similar to and concentric with the load area (Figure 4.22). Since $A_2 > A_1$, the factor $\sqrt{A_2/A_1}$ is greater than unity, indicating that the allowable

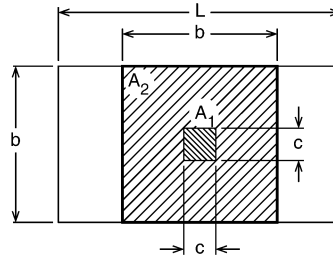

FIGURE 4.22: Bearing areas on footings. $A_1 = c^2$, $A_2 = b^2$.

bearing strength is increased because of the lateral support from the footing area surrounding the column base. If the calculated bearing force is greater than N or the modified one with $r\sqrt{A_2/A_1}$, reinforcement must be provided to transfer the excess force. This is achieved by providing dowels or extending the column bars into the footing. If the calculated bearing force is less than either N or the modified one with $r\sqrt{A_2/A_1}$, then minimum reinforcement must be provided. ACI Code Sec. 15.8.2 indicates that the minimum area of the dowel reinforcement is at least $0.005A_g$ but not less than 4 bars, where A_g is the gross area of the column section of the supported member. The minimum reinforcement requirements apply to the case in which the calculated bearing forces are greater than N or the modified one with $r\sqrt{A_2/A_1}$.

Dowels on Footings

It was explained earlier that dowels are required in any case, even if the bearing strength is adequate. The ACI Code specifies a minimum steel ratio $\rho = 0.005$ of the column section as compared to $\rho = 0.01$ as minimum reinforcement for the column itself. The minimum number of dowel bars needed is four; these may be placed at the four corners of the column. The dowel bars are usually extended into the footing, bent at their ends, and tied to the main footing reinforcement.

ACI Code Sec. 15.8.2 indicates that #14 and #18 longitudinal bars, in compression only, may be lap-spliced with dowels. Dowels should not be larger than #11 bar and should extend (1) into supported member a distance not less than the development length of #14 or 18" bars or the splice length of the dowels—whichever is greater, and (2) into the footing a distance not less than the development length of the dowels.

Development Length of the Reinforcing Bars

The critical sections for checking the development length of reinforcing bars are the same as those for bending moments. Calculated tension or compression in reinforcement at each section should be developed on each side of that section by embedment length, hook (tension only) or mechanical device, or a combination thereof. The development length for compression bar is

$$l_d = 0.02 f_y d_b \sqrt{f'_c} \quad (4.132)$$

but not less than $0.0003 f_y d_b \geq 8$ in. For other values, refer to ACI Code, Chapter 12. Dowel bars must also be checked for proper development length.

Differential Settlement

Footings usually support the following loads:

- Dead loads from the substructure and superstructure
- Live loads resulting from materials or occupancy
- Weight of materials used in backfilling
- Wind loads

Each footing in a building is designed to support the maximum load that may occur on any column due to the critical combination of loadings, using the allowable soil pressure.

The dead load, and maybe a small portion of the live load, may act continuously on the structure. The rest of the live load may occur at intervals and on some parts of the structure only, causing different loadings on columns. Consequently, the pressure on the soil under different loadings will vary according to the loads on the different columns, and differential settlement will occur under the various footings of one structure. Since partial settlement is inevitable, the problem is defined by the amount of differential settlement that the structure can tolerate. The amount of differential settlement depends on the variation in the compressibility of the soils, the thickness of compressible material below foundation level, and the stiffness of the combined footing and superstructure. Excessive differential settlement results in cracking of concrete and damage to claddings, partitions, ceilings, and finishes.

For practical purposes it can be assumed that the soil pressure under the effect of sustained loadings is the same for all footings, thus causing equal settlements. The sustained load (or the usual load) can be assumed equal to the dead load plus a percentage of the live load, which occurs very frequently on the structure. Footings then are proportioned for these sustained loads to produce the same soil pressure under all footings. In no case is the allowable soil bearing capacity to be exceeded under the dead load plus the maximum live load for each footing.

4.10.3 Wall Footings

The spread footing under a wall [Figure 4.16(a)] distributes the wall load horizontally to preclude excessive settlement. The wall should be so located on the footings as to produce uniform bearing pressure on the soil (Figure 4.23), ignoring the variation due to bending of the footing. The pressure is determined by dividing the load per foot by the footing width.

The footing acts as a cantilever on opposite sides of the wall under downward wall loads and upward soil pressure. For footings supporting concrete walls, the critical section for bending moment is at the face of the wall; for footings under masonry walls, halfway between the middle and edge of the

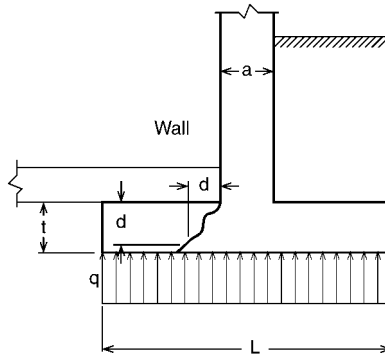

FIGURE 4.23: Reinforced-concrete wall footing.

wall. Hence, for a one-foot-long strip of symmetrical concrete-wall footing, symmetrically loaded, the maximum moment, ft-lb, is

$$M_u = \frac{1}{8} q_u (L - a)^2 \quad (4.133)$$

where q_u is the uniform pressure on soil (lb/ft²), L is the width of footing (ft), and a is wall thickness (ft).

For determining shear stresses, the vertical shear force is computed on the section located at a distance d from the face of the wall. Thus,

$$V_u = q_u \left(\frac{L - a}{2} - L \right) \quad (4.134)$$

The calculation of development length is based on the section of maximum moment.

4.10.4 Single-Column Spread Footings

The spread footing under a column [Figure 4.16(b–d)] distributes the column load horizontally to prevent excessive total and differential settlement. The column should be located on the footing so as to produce uniform bearing pressure on the soil, ignoring the variation due to bending of the footing. The pressure equals the load divided by the footing area.

In plan, single-column footings are usually square. Rectangular footings are used if space restrictions dictate this choice or if the supported columns are of strongly elongated rectangular cross-section. In the simplest form, they consist of a single slab [Figure 4.16(b)]. Another type is that of Figure 4.16(c), where a pedestal or cap is interposed between the column and the footing slab; the pedestal provides for a more favorable transfer of load and in many cases is required in order to provide the necessary development length for dowels. This form is also known as a *stepped footing*. All parts of a stepped footing must be poured in a single pour in order to provide monolithic action. Sometimes sloped footings like those in Figure 4.16(d) are used. They require less concrete than stepped footings, but the additional labor necessary to produce the sloping surfaces (formwork, etc.) usually makes stepped footings more economical. In general, single-slab footings [Figure 4.16(b)] are most economical for thicknesses up to 3 ft.

The required bearing area is obtained by dividing the total load, including the weight of the footing, by the selected bearing pressure. Weights of footings, at this stage, must be estimated and usually amount to 4 to 8% of the column load, the former value applying to the stronger types of soils.

Once the required footing area has been established, the thickness h of the footing must be determined. In single footings the effective depth d is mostly governed by shear. Two different types of

shear strength are distinguished in single footings: two-way (or punching) shear and one-way (or beam) shear. Based on the Equations 4.126 and 4.127 for punching and one-way shear strength, the required effective depth of footing d is calculated.

Single-column footings represent, as it were, cantilevers projecting out from the column in both directions and loaded upward by the soil pressure. Corresponding tension stresses are caused in both these directions at the bottom surface. Such footings are therefore reinforced by two layers of steel, perpendicular to each other and parallel to the edge. The steel reinforcement in each direction can be calculated using Equation 4.129. The critical sections for development length of footing bars are the same as those for bending. Development length may also have to be checked at all vertical planes in which changes of section or of reinforcement occur, as at the edges of pedestals or where part of the reinforcement may be terminated.

When a column rests on a footing or pedestal, it transfers its load to only a part of the total area of the supporting member. The adjacent footing concrete provides lateral support to the directly loaded part of the concrete. This causes triaxial compression stresses that increase the strength of the concrete, which is loaded directly under the column. The design bearing strength of concrete must not exceed the one given in Equation 4.131 for forces acting on the concrete at the base of column and the modified one with $r\sqrt{A_2/A_1}$ for supporting area wider than the loaded area. If the calculated bearing force is greater than the design bearing strength, reinforcement must be provided to transfer the excess force. This is done either by extending the column bars into the footing or by providing dowels, which are embedded in the footing and project above it.

4.10.5 Combined Footings

Spread footings that support more than one column or wall are known as *combined footings*. They can be divided into two categories: those that support two columns, and those that support more than two (generally large numbers of) columns.

In buildings where the allowable soil pressure is large enough for single footings to be adequate for most columns, two-column footings are seen to become necessary in two situations: (1) if columns are so close to the property line that single-column footings cannot be made without projecting beyond that line, and (2) if some adjacent columns are so close to each other that their footings would merge.

When the bearing capacity of the subsoil is low so that large bearing areas become necessary, individual footings are replaced by continuous strip footings, which support more than two columns and usually all columns in a row. Mostly, such strips are arranged in both directions, in which case a grid foundation is obtained, as shown in Figure 4.24. Such a grid foundation can be done by single footings because the individual strips of the grid foundation represent continuous beams whose moments are much smaller than the cantilever moments in large single footings that project far out from the column in all four directions.

For still lower bearing capacities, the strips are made to merge, resulting in a mat foundation, as shown in Figure 4.25. That is, the foundation consists of a solid reinforced concrete slab under the entire building. In structural action such a mat is very similar to a flat slab or a flat plate, upside down—that is, loaded upward by the bearing pressure and downward by the concentrated column reactions. The mat foundation evidently develops the maximum available bearing area under the building. If the soil's capacity is so low that even this large bearing area is insufficient, some form of deep foundation, such as piles or caissons, must be used.

Grid and mat foundations may be designed with the column pedestals—as shown in Figures 4.24 and 4.25—or without them, depending on whether or not they are necessary for shear strength and the development length of dowels. Apart from developing large bearing areas, another advantage of grid and mat foundations is that their continuity and rigidity help in reducing differential settlements of individual columns relative to each other, which may otherwise be caused by local variations in the

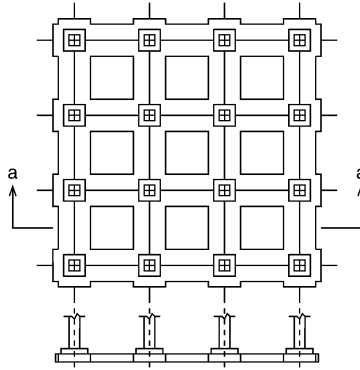

FIGURE 4.24: Grid foundation.

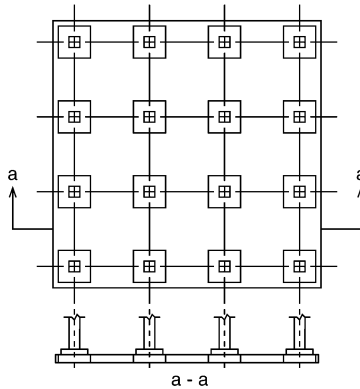

FIGURE 4.25: Mat foundation.

quality of subsoil, or other causes. For this purpose, continuous spread foundations are frequently used in situations where the superstructure or the type of occupancy provides unusual sensitivity to differential settlement.

4.10.6 Two-Column Footings

The ACI Codes does not provide a detailed approach for the design of combined footings. The design, in general, is based on an empirical approach. It is desirable to design combined footings so that the centroid of the footing area coincides with the resultant of the two column loads. This produces uniform bearing pressure over the entire area and forestalls a tendency for the footings to tilt. In plan, such footings are rectangular, trapezoidal, or T shaped, the details of the shape being arranged to produce coincidence of centroid and resultant. The simple relationships of Figure 4.26 facilitate the determination of the shapes of the bearing area [7]. In general, the distances m and n are given, the former being the distance from the center of the exterior column to the property line and the latter the distance from that column to the resultant of both column loads.

Another expedient, which is used if a single footing cannot be centered under an exterior column, is to place the exterior column footing eccentrically and to connect it with the nearest interior column

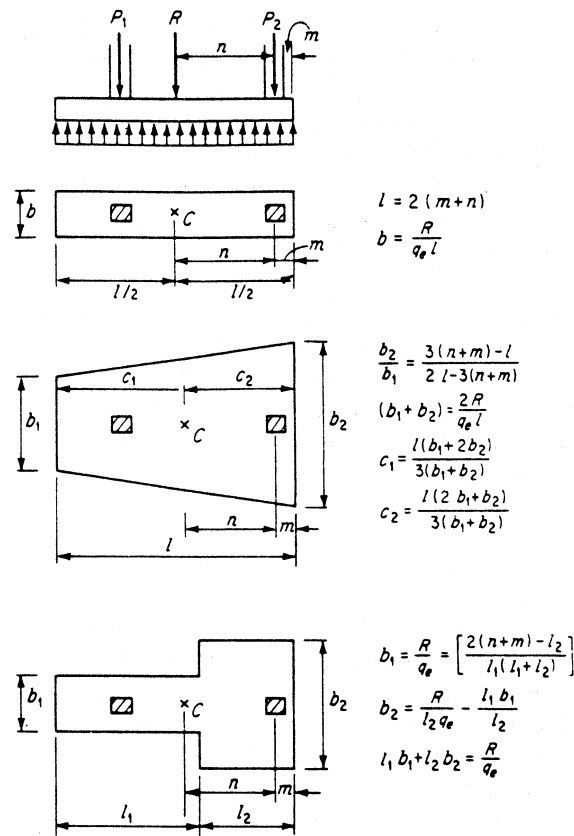

FIGURE 4.26: Two-column footings. (From Fintel, M. 1985. *Handbook of Concrete Engineering*, 2nd ed., Van Nostrand Reinhold, New York. With permission.)

by a beam or strap. This strap, being counterweighted by the interior column load, resists the tilting tendency of the eccentric exterior footings and equalizes the pressure under it. Such foundations are known as *strap*, *cantilever*, or *connected footings*.

The strap may be designed as a rectangular beam spacing between the columns. The loads on it include its own weight (when it does not rest on the soil) and the upward pressure from the footings. Width of the strap usually is selected arbitrarily as equal to that of the largest column plus 4 to 8 inches so that column forms can be supported on top of the strap. Depth is determined by the maximum bending moment. The main reinforcing in the strap is placed near the top. Some of the steel can be cut off where not needed. For diagonal tension, stirrups normally will be needed near the columns (Figure 4.27). In addition, longitudinal placement steel is set near the bottom of the strap, plus reinforcement to guard against settlement stresses.

The footing under the exterior column may be designed as a wall footing. The portions on opposite sides of the strap act as cantilevers under the constant upward pressure of the soil. The interior footing should be designed as a single-column footing. The critical section for punching shear, however, differs from that for a conventional footing. This shear should be computed on a section at a distance $d/2$ from the sides and extending around the column at a distance $d/2$ from its faces, where d is the effective depth of the footing.

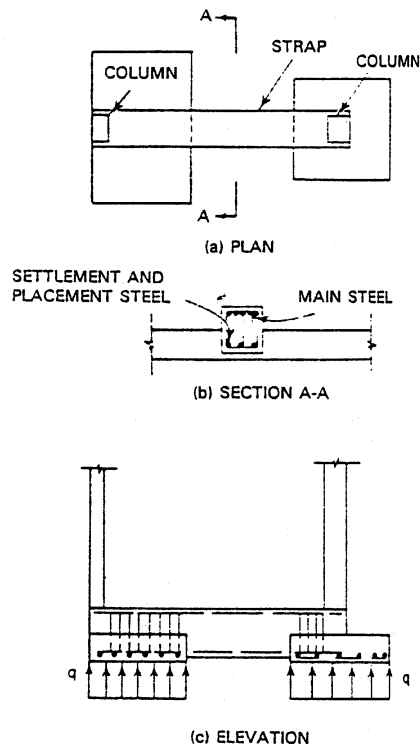

FIGURE 4.27: Strap (cantilever) footing. (From Fintel, M. 1985. *Handbook of Concrete Engineering*, 2nd ed., Van Nostrand Reinhold, New York. With permission.)

4.10.7 Strip, Grid, and Mat Foundations

In the case of heavily loaded columns, particularly if they are to be supported on relatively weak or uneven soils, continuous foundations may be necessary. They may consist of a continuous strip footing supporting all columns in a given row or, more often, of two sets of such strip footings intersecting at right angles so that they form one continuous grid foundation (Figure 4.24). For even larger loads or weaker soils the strips are made to merge, resulting in a mat foundation (Figure 4.25).

For the design of such continuous foundations it is essential that reasonably realistic assumptions be made regarding the distribution of bearing pressures, which act as upward loads on the foundation. For compressible soils it can be assumed in first approximation that the deformation or settlement of the soil at a given location and the bearing pressure at that location are proportional to each other. If columns are spaced at moderate distances and if the strip, grid, or mat foundation is very rigid, the settlements in all portions of the foundation will be substantially the same. This means that the bearing pressure, also known as *subgrade reaction*, will be the same provided that the centroid of the foundation coincides with the resultant of the loads. If they do not coincide, then for such rigid foundations the subgrade reaction can be assumed as linear and determined from statics in the same manner as discussed for single footings. In this case, all loads—the downward column loads as well as the upward-bearing pressures—are known. Hence, moments and shear forces in the foundation can be found by statics alone. Once these are determined, the design of strip and grid foundations is similar to that of inverted continuous beams, and design of mat foundations is similar to that of inverted flat slabs or plates.

On the other hand, if the foundation is relatively flexible and the column spacing large, settlements will no longer be uniform or linear. For one thing, the more heavily loaded columns will cause larger settlements, and thereby larger subgrade reactions, than the lighter ones. Also, since the continuous strip or slab midway between columns will deflect upward relative to the nearby columns, soil settlement—and thereby the subgrade reaction—will be smaller midway between columns than directly at the columns. This is shown schematically in Figure 4.28. In this case the subgrade reaction can no longer be assumed as uniform. A reasonably accurate but fairly complex analysis can then be made using the theory of beams on elastic foundations.

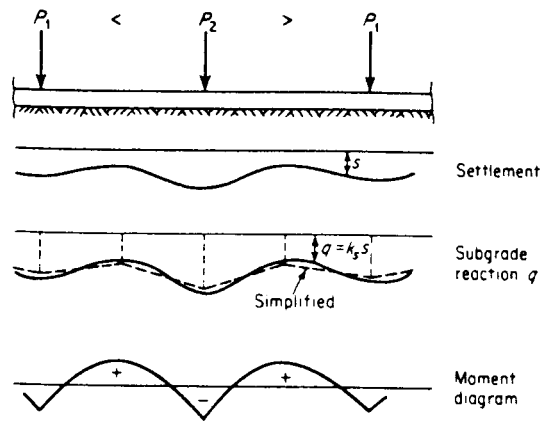

FIGURE 4.28: Strip footing. (From Fintel, M. 1985. *Handbook of Concrete Engineering*, 2nd ed., Van Nostrand Reinhold, New York. With permission.)

A simplified approach has been developed that covers the most frequent situations of strip and grid foundations [4]. The method first defines the conditions under which a foundation can be regarded as rigid so that uniform or overall linear distribution of subgrade reactions can be assumed. This is the case when the average of two adjacent span lengths in a continuous strip does not exceed $1.75/\lambda$, provided also that the adjacent span and column loads do not differ by more than 20% of the larger value. Here,

$$\lambda = 4\sqrt{\frac{k_s b}{3E_c I}} \quad (4.135)$$

where

$$k_s = Sk'_s$$

k'_s = coefficient of subgrade reaction as defined in soils mechanics, basically force per unit area required to produce unit settlement, kips/ft³

b = width of footing, ft

E_c = modulus of elasticity of concrete, kips/ft²

I = moment of inertia of footing, ft⁴

S = shape factor, being $[(b + 1)/2b]^2$ for granular soils and $(n + 0.5)/1.5n$ for cohesive soils, where n is the ratio of longer to shorter side of strip

If the average of two adjacent spans exceeds $1.75/\lambda$, the foundation is regarded as flexible. Provided that adjacent spans and column loads differ by no more than 20%, the complex curvilinear distribution of subgrade reaction can be replaced by a set of equivalent trapezoidal reactions, which are also shown in Figure 4.28. The report of ACI Committee 436 contains fairly simple equations

for determining the intensities of the equivalent pressures under the columns and at the middle of the spans and also gives equations for the positive and negative moments caused by these equivalent subgrade reactions. With this information, the design of continuous strip and grid footings proceeds similarly to that of footings under two columns.

Mat foundations likewise require different approaches, depending on whether they can be classified as rigid or flexible. As in strip footings, if the column spacing is less than $1/\lambda$, the structure may be regarded as rigid, soil pressure can be assumed as uniformly or linearly distributed, and the design is based on statics. On the other hand, when the foundation is considered flexible as defined above, and if the variation of adjacent column loads and spans is not greater than 20%, the same simplified procedure as for strip and grid foundations can be applied to mat foundations. The mat is divided into two sets of mutually perpendicular strip footings of width equal to the distance between midspans, and the distribution of bearing pressures and bending moments is carried out for each strip. Once moments are determined, the mat is in essence treated the same as a flat slab or plate, with the reinforcement allocated between column and middle strips as in these slab structures.

This approach is feasible only when columns are located in a regular rectangular grid pattern. When a mat that can be regarded as rigid supports columns at random locations, the subgrade reactions can still be taken as uniform or as linearly distributed and the mat analyzed by statics. If it is a flexible mat that supports such randomly located columns, the design is based on the theory of plates on elastic foundation.

4.10.8 Footings on Piles

If the bearing capacity of the upper soil layers is insufficient for a spread foundation, but firmer strata are available at greater depth, piles are used to transfer the loads to these deeper strata. Piles are generally arranged in groups or clusters, one under each column. The group is capped by a spread footing or cap that distributes the column load to all piles in the group. Reactions on caps act as concentrated loads at the individual piles, rather than as distributed pressures. If the total of all pile reactions in a cluster is divided by area of the footing to obtain an equivalent uniform pressure, it is found that this equivalent pressure is considerably higher in pile caps than for spread footings.

Thus, it is in any event advisable to provide ample rigidity—that is, depth for pile caps—in order to spread the load evenly to all piles.

As in single-column spread footings, the effective portion of allowable bearing capacities of piles, R_a , available to resist the unfactored column loads is the allowable pile reaction less the weight of footing, backfill, and surcharge per pile. That is,

$$R_e = R_a - W_f \quad (4.136)$$

where W_f is the total weight of footing, fill, and surcharge divided by the number of piles.

Once the available or effective pile reaction R_e is determined, the number of piles in a concentrically loaded cluster is the integer next larger than

$$n = \frac{D + L}{R_e} \quad (4.137)$$

The effects of wind and earthquake moments at the foot of the columns generally produce an eccentrically loaded pile cluster in which different piles carry different loads. The number and location of piles in such a cluster is determined by successive approximation from the condition that the load on the most heavily loaded pile should not exceed the allowable pile reaction R_a . Assuming a linear distribution of pile loads due to bending, the maximum pile reaction is

$$R_{\max} = \frac{P}{n} + \frac{M}{I_{pg}/c} \quad (4.138)$$

where P is the maximum load (including weight of cap, backfill, etc.), M is the moment to be resisted by the pile group, both referred to the bottom of the cap, I_{pg} is the moment of inertia of the entire pile group about the centroidal axis about which bendings occurs, and c is the distance from that axis to the extreme pile.

Piles are generally arranged in tight patterns, which minimizes the cost of the caps, but they cannot be placed closer than conditions of deriving and of undisturbed carrying capacity will permit. AASHTO requires that piles be spaced at least 2 ft 6 in. center to center and that the distance from the side of a pile to the nearest edge of the footing be 9 in. or more.

The design of footings on piles is similar to that of single-column spread footings. One approach is to design the cap for the pile reactions calculated for the factored column loads. For a concentrically loaded cluster this would give $R_u = (1.4D + 1.7L)/n$. However, since the number of piles was taken as the next larger integer according to Equation 4.138, determining R_u in this manner can lead to a design where the strength of the cap is less than the capacity of the pile group. It is therefore recommended that the pile reaction for strength design be taken as

$$R_u = R_e \times \text{Average load factor} \quad (4.139)$$

where the average load factor is $(1.4D + 1.7L)/(D + L)$. In this manner the cap is designed to be capable of developing the full allowable capacity of the pile group.

As in single-column spread footings, the depth of the pile cap is usually governed by shear. In this regard both punching and one-way shear need to be considered. The critical sections are the same as explained earlier under “Two-Way Shear (Punching Shear)” and “One-Way Shear.” The difference is that shears on caps are caused by concentrated pile reactions rather than by distributed bearing pressures. This poses the question of how to calculate shear if the critical section intersects the circumference of one or more piles. For this case the ACI Code accounts for the fact that pile reaction is not really a point load, but is distributed over the pile-bearing area. Correspondingly, for piles with diameters d_p , it stipulates as follows:

Computation of shear on any section through a footing on piles shall be in accordance with the following:

- (a) The entire reaction from any pile whose center is located $d_p/2$ or more outside this section shall be considered as producing shear on that section.
- (b) The reaction from any pile whose center is located $d_p/2$ or more inside the section shall be considered as producing no shear on that section.
- (c) For intermediate portions of the pile center, the portion of the pile reaction to be considered as producing shear on the section shall be based on straight-line interpolation between the full value at $d_p/2$ outside the section and zero at $d_p/2$ inside the section [1].

In addition to checking punching and one-way shear, punching shear must be investigated for the individual pile. Particularly in caps on a small number of heavily loaded piles, it is this possibility of a pile punching upward through the cap which may govern the required depth. The critical perimeter for this action, again, is located at a distance $d/2$ outside the upper edge of the pile. However, for relatively deep caps and closely spaced piles, critical perimeters around adjacent piles may overlap. In this case, fracture, if any, would undoubtedly occur along an outward-slanting surface around both adjacent piles. For such situations the critical perimeter is so located that its length is a minimum, as shown for two adjacent piles in Figure 4.29.

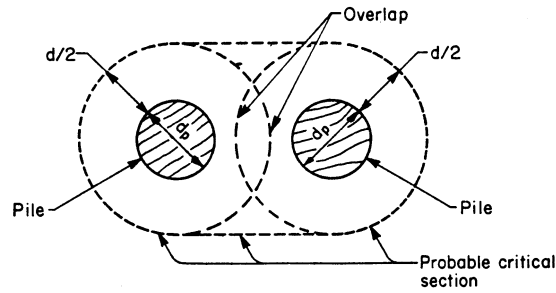

FIGURE 4.29: Modified critical section for shear with overlapping critical perimeters.

4.11 Walls

4.11.1 Panel, Curtain, and Bearing Walls

As a general rule, the exterior walls of a reinforced concrete building are supported at each floor by the skeleton framework, their only function being to enclose the building. Such walls are called *panel walls*. They may be made of concrete (often precast), cinder concrete block, brick, tile blocks, or insulated metal panels. The thickness of each of these types of panel walls will vary according to the material, type of construction, climatological conditions, and the building requirements governing the particular locality in which the construction takes place. The pressure of the wind is usually the only load that is considered in determining the structural thickness of a wall panel, although in some cases exterior walls are used as diaphragms to transmit forces caused by horizontal loads down to the building foundations.

Curtain walls are similar to panel walls except that they are not supported at each story by the frame of the building; rather, they are self supporting. However, they are often anchored to the building frame at each floor to provide lateral support.

A bearing wall may be defined as one that carries any vertical load in addition to its own weight. Such walls may be constructed of stone masonry, brick, concrete block, or reinforced concrete. Occasional projections or pilasters add to the strength of the wall and are often used at points of load concentration. Bearing walls may be of either single or double thickness, the advantage of the latter type being that the air space between the walls renders the interior of the building less liable to temperature variation and makes the wall itself more nearly moistureproof. On account of the greater gross thickness of the double wall, such construction reduces the available floor space.

According to ACI Code Sec. 14.5.2 the load capacity of a wall is given by

$$\phi P_{nw} = 0.55\phi f'_c A_g \left[1 - \left(\frac{kl_c}{32h} \right)^2 \right] \quad (4.140)$$

where

ϕP_{nw} = design axial load strength

A_g = gross area of section, in.²

l_c = vertical distance between supports, in.

h = thickness of wall, in.

ϕ = 0.7

and where the effective length factor k is taken as 0.8 for walls restrained against rotation at top or bottom or both, 1.0 for walls unrestrained against rotation at both ends, and 2.0 for walls not braced against lateral translation.

In the case of concentrated loads, the length of the wall to be considered as effective for each should not exceed the center-to-center distance between loads; nor should it exceed the width of the bearing plus 4 times the wall thickness. Reinforced concrete bearing walls should have a thickness of at least 1/25 times the unsupported height or width, whichever is shorter. Reinforced concrete bearing walls of buildings should be not less than 4 in. thick.

Minimum ratio of horizontal reinforcement area to gross concrete area should be 0.0020 for deformed bars not larger than #5—with specified yield strength not less than 60,000 psi or 0.0025 for other deformed bars—or 0.0025 for welded wire fabric not larger than W31 or D31. Minimum ratio of vertical reinforcement area to gross concrete area should be 0.0012 for deformed bars not larger than #5—with specified yield strength not less than 60,000 psi or 0.0015 for other deformed bars—or 0.0012 for welded wire fabric not larger than W31 or D31. In addition to the minimum reinforcement, not less than two #5 bars shall be provided around all window and door openings. Such bars shall be extended to develop the bar beyond the corners of the openings but not less than 24 in.

Walls more than 10 in. thick should have reinforcement for each direction placed in two layers parallel with faces of wall. Vertical and horizontal reinforcement should not be spaced further apart than three times the wall thickness, or 18 in. Vertical reinforcement need not be enclosed by lateral ties if vertical reinforcement area is not greater than 0.01 times gross concrete area, or where vertical reinforcement is not required as compression reinforcement.

Quantity of reinforcement and limits of thickness mentioned above are waived where structural analysis shows adequate strength and stability. Walls should be anchored to intersecting elements such as floors, roofs, or to columns, pilasters, buttresses, and intersecting walls, and footings.

4.11.2 Basement Walls

In determining the thickness of basement walls, the lateral pressure of the earth, if any, must be considered in addition to other structural features. If it is part of a bearing wall, the lower portion may be designed either as a slab supported by the basement and floors or as a retaining wall, depending upon the type of construction. If columns and wall beams are available for support, each basement wall panel of reinforced concrete may be designed to resist the earth pressure as a simple slab reinforced in either one or two directions. A minimum thickness of 7.5 in. is specified for reinforced concrete basement walls. In wet ground a minimum thickness of 12 in. should be used. In any case, the thickness cannot be less than that of the wall above.

Care should be taken to brace a basement wall thoroughly from the inside (1) if the earth is backfilled before the wall has obtained sufficient strength to resist the lateral pressure without such assistance, or (2) if it is placed before the first-floor slab is in position.

4.11.3 Partition Walls

Interior walls used for the purpose of subdividing the floor area may be made of cinder block, brick, precast concrete, metal lath and plaster, clay tile, or metal. The type of wall selected will depend upon the fire resistance required; flexibility of rearrangement; ease with which electrical conduits, plumbing, etc. can be accommodated; and architectural requirements.

4.11.4 Shears Walls

Horizontal forces acting on buildings—for example, those due to wind or seismic action—can be resisted by a variety of means. Rigid-frame resistance of the structure, augmented by the contribution of ordinary masonry walls and partitions, can provide for wind loads in many cases. However, when heavy horizontal loading is likely—such as would result from an earthquake—reinforced concrete

shear walls are used. These may be added solely to resist horizontal forces; alternatively, concrete walls enclosing stairways or elevator shafts may also serve as shear walls.

Figure 4.30 shows a building with wind or seismic forces represented by arrows acting on the edge of each floor or roof. The horizontal surfaces act as deep beams to transmit loads to vertical resisting

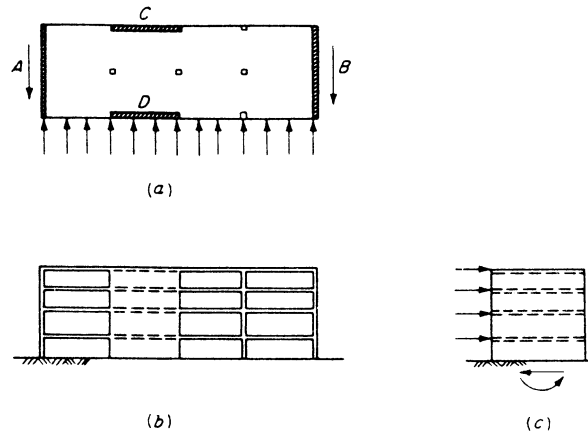

FIGURE 4.30: Building with shear walls subject to horizontal loads: (a) typical floor; (b) front elevation; (c) end elevation.

elements A and B. These shear walls, in turn, act as cantilever beams fixed at their base to carry loads down to the foundation. They are subjected to (1) a variable shear, which reaches maximum at the base, (2) a bending moment, which tends to cause vertical tension near the loaded edge and compression at the far edge, and (3) a vertical compression due to ordinary gravity loading from the structure. For the building shown, additional shear walls C and D are provided to resist loads acting in the log direction of the structure.

The design basis for shear walls, according to the ACI Code, is of the same general form as that used for ordinary beams:

$$V_u \leq \phi V_n \quad (4.141)$$

$$V_n = V_c + V_s \quad (4.142)$$

Shear strength V_n at any horizontal section for shear in plane of wall should not be taken greater than $10\sqrt{f'_c}hd$. In this and all other equations pertaining to the design of shear walls, the distance of d may be taken equal to $0.8l_w$. A larger value of d , equal to the distance from the extreme compression face to the center of force of all reinforcement in tension, may be used when determined by a strain compatibility analysis.

The value of V_c , the nominal shear strength provided by the concrete, may be based on the usual equations for beams, according to ACI Code. For walls subjected to vertical compression,

$$V_c = 2\sqrt{f'_c}hd \quad (4.143)$$

and for walls subjected to vertical tension N_u ,

$$V_c = 2 \left(1 + \frac{N_u}{500A_g} \right) \sqrt{f'_c}hd \quad (4.144)$$

where N_u is the factored axial load in pounds, taken negative for tension, and A_g is the gross area of horizontal concrete section in square inches. Alternatively, the value of V_c may be based on a more detailed calculation, as the lesser of

$$V_c = 3.3\sqrt{f'_c}hd + \frac{N_u d}{4l_w} \quad (4.145)$$

or

$$V_c = \left[0.6\sqrt{f'_c} + \frac{l_w (1.25\sqrt{f'_c} + 0.2N_u/l_w h)}{M_u/V_u - l_w/2} \right] hd \quad (4.146)$$

Equation 4.145 corresponds to the occurrence of a principal tensile stress of approximately $4\sqrt{f'_c}$ at the centroid of the shear-wall section. Equation 4.146 corresponds approximately to the occurrence of a flexural tensile stress of $6\sqrt{f'_c}$ at a section $l_w/2$ above the section being investigated. Thus the two equations predict, respectively, web-shear cracking and flexure-shear cracking. When the quantity $M_u/V_u - l_w/2$ is negative, Equation 4.146 is inapplicable. According to the ACI Code, horizontal sections located closer to the wall base than a distance $l_w/2$ or $h_w/2$, whichever less, may be designed for the same V_c as that computed at a distance $l_w/2$ or $h_w/2$.

When the factored shear force V_u does not exceed $\phi V_c/2$, a wall may be reinforced according to the minimum requirements given in Sec. 12.1. When V_u exceeds $\phi V_c/2$, reinforcement for shear is to be provided according to the following requirements.

The nominal shear strength V_s provided by the horizontal wall steel is determined on the same basis as for ordinary beams:

$$V_s = \frac{A_v f_y d}{s_2} \quad (4.147)$$

where A_v is the area of horizontal shear reinforcement within vertical distance s_2 , (in.²), s_2 is the vertical distance between horizontal reinforcement, (in.), and f_y is the yield strength of reinforcement, psi. Substituting Equation 4.147 into Equation 4.142, then combining with Equation 4.141, one obtains the equation for the required area of horizontal shear reinforcement within a distance s_2 :

$$A_v = \frac{(V_u - \phi V_c) s_2}{\phi f_y d} \quad (4.148)$$

The minimum permitted ratio of horizontal shear steel to gross concrete area of vertical section, ρ_n , is 0.0025 and the maximum spacing s_2 is not exceed $l_w/5$, $3h$, or 18 in.

Test results indicate that for low shear walls, vertical distributed reinforcement is needed as well as horizontal reinforcement. Code provisions require vertical steel of area A_h within a spacing s_1 , such that the ratio of vertical steel to gross concrete area of horizontal section will not be less than

$$\rho_n = 0.0025 + 0.5 \left(2.5 - \frac{h_w}{l_w} \right) (\rho_h - 0.0025) \quad (4.149)$$

nor less than 0.0025. However, the vertical steel ratio need not be greater than the required horizontal steel ratio. The spacing of the vertical bars is not to exceed $l_w/3$, $3h$, or 18 in.

Walls may be subjected to flexural tension due to overturning moment, even when the vertical compression from gravity loads is superimposed. In many but not all cases, vertical steel is provided, concentrated near the wall edges, as in Figure 4.31. The required steel area can be found by the usual methods for beams.

The ACI Code contains requirements for the dimensions and details of structural walls serving as part of the earthquake-force resisting systems. The reinforcement ratio, $\rho_v (= A_{sv}/A_{cv}$; where A_{cv} is the net area of concrete section bounded by web thickness and length of section in the direction of

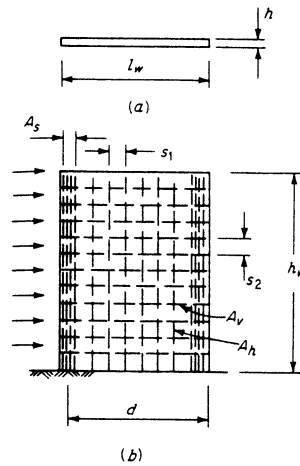

FIGURE 4.31: Geometry and reinforcement of typical shear wall: (a) cross section; (b) elevation.

shear force considered, and A_{sv} is the projection on A_{cv} of area of distributed shear reinforcement crossing the plane of A_{cv}), for structural walls should not be less than 0.0025 along the longitudinal and transverse axes. Reinforcement provided for shear strength should be continuous and should be distributed across the shear plane. If the design shear force does not exceed $A_{cv}\sqrt{f'_c}$, the shear reinforcement may conform to the reinforcement ratio given in Sec. 12.1. At least two curtains of reinforcement should be used in a wall if the in-plane factored shear force assigned to the wall exceeds $2A_{cv}\sqrt{f'_c}$. All continuous reinforcement in structural walls should be anchored or spliced in accordance with the provisions for reinforcement in tension for seismic design.

Proportioning and details of structural walls that resist shear forces caused by earthquake motion is contained in the ACI Code Sec. 21.7.3.

4.12 Defining Terms

The terms common in concrete engineering as defined in and selected from the Cement and Concrete Terminology Report of ACI Committee 116 are given below [1, Further Reading].

Allowable stress: Maximum permissible stress used in design of members of a structure and based on a factor of safety against yielding or failure of any type.

Allowable stress design (ASD): Design principle according to which stresses resulting from service or working loads are not allowed to exceed specified allowable values.

Balanced load: Combination of axial force and bending moment that causes simultaneous crushing of concrete and yielding of tension steel.

Balanced reinforcement: An amount and distribution of flexural reinforcement such that the tensile reinforcement reaches its specified yield strength simultaneously with the concrete in compression reaching its assumed ultimate strain of 0.003.

Beam: A structural member subjected primarily to flexure; depth-to-span ratio is limited to 2/5 for continuous spans, or 4/5 for simple spans, otherwise the member is to be treated as a deep beam.

Beam-column: A structural member that is subjected simultaneously to bending and substantial axial forces.

Bond: Adhesion and grip of concrete or **mortar** to reinforcement or to other surfaces against which it is placed; to enhance bond strength, ribs or other deformations are added to reinforcing bars.

Camber: A deflection that is intentionally built into a structural element or form to improve appearance or to offset the deflection of the element under the effects of loads, shrinkage, and creep.

Cast-in-place concrete: Concrete poured in its final or permanent location; also called *in situ* concrete; opposite of precast concrete.

Column: A member used to support primarily axial compression loads with a height of at least three times its least lateral dimensions; the capacity of short columns is controlled by strength; the capacity of long columns is limited by buckling.

Column strip: The portion of a flat slab over a row of columns consisting of the two adjacent quarter panels on each side of the column centerline.

Composition construction: A type of construction using members made of different materials (e.g., concrete and structural steel), or combining members made of cast-in-place concrete and precast concrete such that the combined components act together as a single member; strictly speaking, reinforced concrete is also composite construction.

Compression member: A member subjected primarily to longitudinal compression; often synonymous with “column”.

Compressive strength: Strength typically measured on a standard 6 × 12 in. cylinder of concrete in an axial compression test, 28 d after casting.

Concrete: A composite material that consists essentially of a binding medium within which are embedded particles or fragments of aggregate; in portland cement concrete, the binder is a mixture of portland cement and water.

Confined concrete: Concrete enclosed by closely spaced transverse reinforcement, which restrains the concrete expansion in directions perpendicular to the applied stresses.

Construction joint: The surface where two successive placements of concrete meet, across which it may be desirable to achieve bond, and through which reinforcement may be continuous.

Continuous beam or slab: A beam or slab that extends as a unit over three or more supports in a given direction and is provided with the necessary reinforcement to develop the negative moments over the interior supports; a redundant structure that requires a statically indeterminate analysis (opposite of simple supported beam or slab).

Cover: In reinforced concrete, the shortest distance between the surface of the reinforcement and the outer surface of the concrete; minimum values are specified to protect the reinforcement against corrosion and to assure sufficient bond strength.

Cracks: Results of stresses exceeding concrete’s tensile strength capacity; cracks are ubiquitous in reinforced concrete and needed to develop the strength of the reinforcement, but a design goal is to keep their widths small (hairline cracks).

Cracked section: A section designed or analyzed on the assumption that concrete has no resistance to tensile stress.

Cracking load: The load that causes tensile stress in a member to be equal to the tensile strength of the concrete.

Deformed bar: Reinforcing bar with a manufactured pattern of surface ridges intended to prevent slip when the bar is embedded in concrete.

Design strength: Ultimate load-bearing capacity of a member multiplied by a strength reduction factor.

Development length: The length of embedded reinforcement to develop the design strength of the reinforcement; a function of bond strength.

Diagonal crack: An inclined crack caused by a diagonal tension, usually at about 45 degrees to the neutral axis of a concrete member.

Diagonal tension: The principal tensile stress resulting from the combination of normal and shear stresses acting upon a structural element.

Drop panel: The portion of a flat slab in the area surrounding a column, column capital, or bracket which is thickened in order to reduce the intensity of stresses.

Ductility: Capability of a material or structural member to undergo large inelastic deformations without distress; opposite of brittleness; very important material property, especially for earthquake-resistant design; steel is naturally ductile, concrete is brittle but it can be made ductile if well confined.

Durability: The ability of concrete to maintain its qualities over long time spans while exposed to weather, freeze-thaw cycles, chemical attack, abrasion, and other service load conditions.

Effective depth: Depth of a beam or slab section measured from the compression face to the centroid of the tensile reinforcement.

Effective flange width: Width of slab adjoining a beam stem assumed to function as the flange of a T-section.

Effective prestress: The stress remaining in the prestressing steel or in the concrete due to prestressing after all losses have occurred.

Effective span: The lesser of the distance between centers of supports and the clear distance between supports plus the effective depth of the beam or slab.

Flat slab: A concrete slab reinforced in two or more directions, generally without beams or girders to transfer the loads to supporting members, but with drop panels or column capitals or both.

High-early strength cement: Cement producing strength in mortar or concrete earlier than regular cement.

Hoop: A one-piece closed reinforcing tie or continuously wound tie that encloses the longitudinal reinforcement.

Interaction diagram: Failure curve for a member subjected to both axial force and the bending moment, indicating the moment capacity for a given axial load and vice versa; used to develop design charts for reinforced concrete compression members.

Lightweight concrete: Concrete of substantially lower unit weight than that made using normal-weight gravel or crushed stone aggregate.

Limit analysis: See Plastic analysis.

Limit design: A method of proportioning structural members based on satisfying certain strength and serviceability limit states.

Load and resistance factor design (LRFD): See Ultimate strength design.

Load factor: A factor by which a service load is multiplied to determine the factored load used in ultimate strength design.

Modulus of elasticity: The ratio of normal stress to corresponding strain for tensile or compressive stresses below the proportional limit of the material; for steel, $E_s = 29,000$ ksi; for concrete it is highly variable with stress level and the strength f'_c ; for normal-weight concrete and low stresses, a common approximation is $E_c = 57,000\sqrt{f'_c}$.

Modulus of rupture: The tensile strength of concrete as measured in a flexural test of a small prismatic specimen of plain concrete.

Mortar: A mixture of cement paste and fine aggregate; in fresh concrete, the material occupying the interstices among particles of coarse aggregate.

Nominal strength: The strength of a structural member based on its assumed material properties and sectional dimensions, before application of any strength reduction factor.

Plastic analysis: A method of structural analysis to determine the intensity of a specified load distribution at which the structure forms a collapse mechanism.

Plastic hinge: Region of flexural member where the ultimate moment capacity can be developed and maintained with corresponding significant inelastic rotation, as main tensile steel is stressed beyond the yield point.

Post-tensioning: A method of prestressing reinforced concrete in which the tendons are tensioned after the concrete has hardened (opposite of pretensioning).

Precast concrete: Concrete cast elsewhere than its final position, usually in factories or factory-like shop sites near the final site (opposite of cast-in-place concrete).

Prestressed concrete: Concrete in which internal stresses of such magnitude and distribution are introduced that the tensile stresses resulting from the service loads are counteracted to a desired degree; in reinforced concrete the prestress is commonly introduced by tensioning embedded tendons.

Prestressing steel: High strength steel used to prestress concrete, commonly seven-wire strands, single wires, bars, rods, or groups of wires or strands.

Pretensioning: A method of prestressing reinforced concrete in which the tendons are tensioned before the concrete has hardened (opposite of post-tensioning).

Ready-mixed concrete: Concrete manufactured for delivery to a purchaser in a plastic and unhardened state; usually delivered by truck.

Rebar: Short for reinforcing bar; see Reinforcement.

Reinforced concrete: Concrete containing adequate reinforcement (prestressed or not) and designed on the assumption that the two materials act together in resisting forces.

Reinforcement: Bars, wires, strands, and other slender members that are embedded in concrete in such a manner that the reinforcement and the concrete act together in resisting forces.

Safety factor: The ratio of a load producing an undesirable state (such as collapse) and an expected or service load.

Service loads: Loads on a structure with high probability of occurrence, such as dead weight supported by a member or the live loads specified in building codes and bridge specifications.

Shear key: A recess or groove in a joint between successive lifts or placements of concrete, which is filled with concrete of the adjacent lift, giving shear strength to the joint.

Shear span: The distance from a support of a simply supported beam to the nearest concentrated load.

Shear wall: See Structural wall.

Shotcrete: Mortar or concrete pneumatically projected at high velocity onto a surface.

Silica fume: Very fine noncrystalline silica produced in electric arc furnaces as a by-product of the production of metallic silicon and various silicon alloys (also known as condensed silica fume); used as a mineral admixture in concrete.

Slab: A flat, horizontal (or nearly so) molded layer of plain or reinforced concrete, usually of uniform thickness, either on the ground or supported by beams, columns, walls, or other frame work. See also Flat slab.

Slump: A measure of consistency of freshly mixed concrete equal to the subsidence of the molded specimen immediately after removal of the slump cone, expressed in inches.

Splice: Connection of one reinforcing bar to another by lapping, welding, mechanical couplers, or other means.

Split cylinder test: Test for tensile strength of concrete in which a standard cylinder is loaded to failure in diametral compression applied along the entire length (also called Brazilian test).

Standard cylinder: Cylindrical specimen of 12-in. height and 6-in. diameter, used to determine standard compressive strength and splitting tensile strength of concrete.

Stiffness coefficient: The coefficient k_{ij} of stiffness matrix K for a multi-degree of freedom structure is the force needed to hold the i th degree of freedom in place, if the j th degree of freedom undergoes a unit of displacement, while all others are locked in place.

Stirrup: A reinforcement used to resist shear and diagonal tension stresses in a structural member; typically a steel bar bent into a U or rectangular shape and installed perpendicular to or at an angle to the longitudinal reinforcement, and properly anchored; the term “stirrup” is usually applied to lateral reinforcement in flexural members and the term “tie” to lateral reinforcement in compression members. See Tie.

Strength design: See Ultimate strength design.

Strength reduction factor: Capacity reduction factor (typically designated as ϕ) by which the nominal strength of a member is to be multiplied to obtain the design strength; specified by the ACI Code for different types of members.

Structural concrete: Concrete used to carry load or to form an integral part of a structure (opposite of, for example, insulating concrete).

T-beam: A beam composed of a stem and a flange in the form of a “T”, with the flange usually provided by a slab.

Tension stiffening effect: The added stiffness of a single reinforcing bar due to the surrounding uncracked concrete between bond cracks.

Tie: Reinforcing bar bent into a loop to enclose the longitudinal steel in columns; tensile bar to hold a form in place while resisting the lateral pressure of unhardened concrete.

Ultimate strength design (USD): Design principle such that the actual (ultimate) strength of a member or structure, multiplied by a strength factor, is no less than the effects of all service load combinations, multiplied by respective overload factors.

Unbonded tendon: A tendon that is not bonded to the concrete.

Under-reinforced beam: A beam with less than **balanced reinforcement** such that the reinforcement yields before the concrete crushes in compression.

Water-cement ratio: Ratio by weight of water to cement in a mixture; inversely proportional to concrete strength.

Water-reducing admixture: An admixture capable of lowering the mix viscosity, thereby allowing a reduction of water (and increase in strength) without lowering the workability (also called superplasticizer).

Whitney stress block: A rectangular area of uniform stress intensity $0.85 f'_c$, whose area and centroid are similar to that of the actual stress distribution in a flexural member near failure.

Workability: General property of freshly mixed concrete that defines the ease with which it can be placed into forms without honeycombs; closely related to slump.

Working stress design: See Allowable stress design.

Yield-line theory: Method of structural analysis of plate structures at the verge of collapse under factored loads.

References

- [1] ACI Committee 318. 1992. *Building Code Requirements for Reinforced Concrete and Commentary, ACI 318-89 (Revised 92) and ACI 318R-89 (Revised 92)* (347pp.). Detroit, MI.
- [2] ACI Committee 340. 1990. *Design Handbook in Accordance with the Strength Design Method of ACI 318-89*. Volume 2, SP-17 (222 pp.).
- [3] ACI Committee 363. 1984. State-of-the-art report on high strength concrete. *ACI J. Proc.* 81(4):364-411.
- [4] ACI Committee 436. 1996. Suggested design procedures for combined footings and mats. *J. ACI*. 63:1041-1057.
- [5] Breen, J.E. 1991. Why structural concrete? *IASE Colloq. Struct. Concr.* Stuttgart, pp.15-26.

- [6] Collins, M.P. and Mitchell, D. 1991. *Prestressed Concrete Structures*, 1st ed., Prentice Hall, Englewood Cliffs, N.J.
- [7] Fintel, M. 1985. *Handbook of Concrete Engineering*. 2nd ed., Van Nostrand Reinhold, New York.
- [8] MacGregor, J.G. 1992. *Reinforced Concrete Mechanics and Design*, 2nd ed., Prentice Hall, Englewood Cliffs, N.J.
- [9] Nilson, A.H. and Winter, G. 1992. *Design of Concrete Structures*, 11th ed., McGraw-Hill, New York.
- [10] *Standard Handbook for Civil Engineers*, 2nd ed., McGraw-Hill, New York.
- [11] Wang, C.-K. and Salmon, C. G. 1985. *Reinforced Concrete Design*, 4th ed., Harper Row, New York.

Further Reading

- [1] ACI Committee 116. 1990. Cement and Concrete Terminology, Report 116R-90, American Concrete Institute, Detroit, MI.
- [2] Ferguson, P.M., Breen, J.E., and Jirsa, J.O. 1988. *Reinforced Concrete Fundamentals*, 5th ed., John Wiley & Sons, New York.
- [3] Lin, T-Y. and Burns, N.H. 1981. *Design of Prestressed Concrete Structures*, 3rd ed., John Wiley & Sons, New York.
- [4] Meyer, C. 1996. *Design of Concrete Structures*, Prentice-Hall, Upper Saddle River, NJ.